

aroSTOR

VWL B 200/5 UK
VWL B 270/5 UK

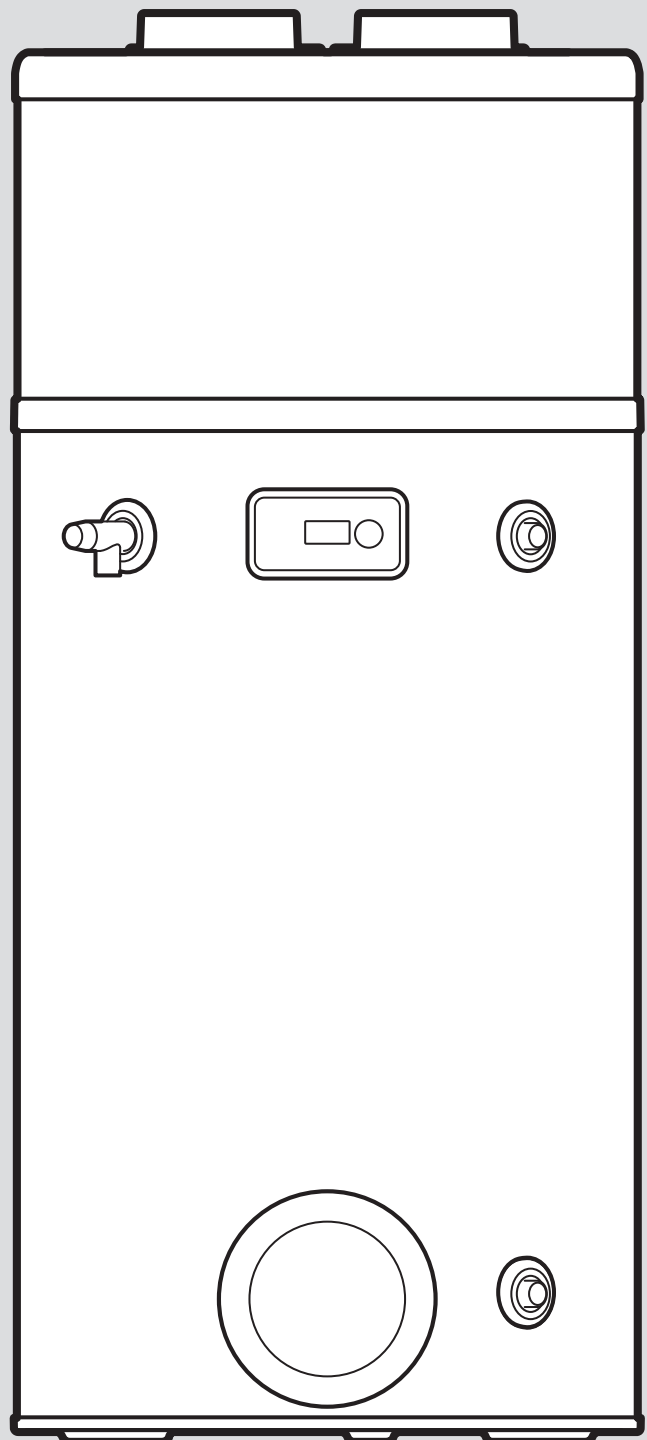

Installation and maintenance instructions

Contents

1	Safety	3	9.3	Resetting the safety cut-out	21
1.1	Intended use	3	9.4	Replacing the power supply cable	22
1.2	General safety information	3	9.5	Completing repair work	22
1.3	Regulations (directives, laws, standards)	5	10	Inspection and maintenance	22
2	Notes on the documentation	6	10.1	Preparing the maintenance and repair work	22
2.1	Observing other applicable documents	6	10.2	Observing inspection and maintenance intervals	22
2.2	Storing documents	6	10.3	Draining the product	22
2.3	Validity of the instructions	6	10.4	Procuring spare parts	22
3	Product description	6	10.5	Checking the safety group's expansion relief valve and the cylinder's expansion relief valve	22
3.1	Product design	6	10.6	Checking the pre-charge pressure of the expansion vessel	22
3.2	Operation	6	10.7	Checking the inside of the cylinder	23
3.3	Basic system diagram	7	11	Decommissioning	23
3.4	Type designation and serial number	8	11.1	Decommissioning the product	23
3.5	CE marking	8	11.2	Arranging disposal of refrigerant	23
3.6	Hot Water Association	8	12	Customer service	23
3.7	Benchmark	8	13	Disposing of the packaging	23
4	Set-up	8	Appendix	24	
4.1	Transporting the product to the installation site	8	A	Annual inspection and maintenance work – Overview	24
4.2	Carrying the product	8	B	Fault messages – Overview	24
4.3	Unpacking the product	9	C	Installer level – Overview	27
4.4	Checking the scope of delivery	9	D	Electronics box wiring diagram	28
4.5	Product dimensions and connection dimensions	10	E	Heat pump output curves	29
4.6	Requirements for the installation site	10	F	Maximum water temperature	29
4.7	Removing/installing the protective cover	10	G	Commissioning Checklist	30
5	Installation	10	H	Technical data	33
5.1	Installing the air supply and air exhaust	11	Index	35	
5.2	Installing the water connections	13			
5.3	Electrical installation	16			
6	Start-up	17			
6.1	Checking and preparing the cold water supply	17			
6.2	Filling the domestic hot water circuit	18			
6.3	Switching on the product	18			
7	Handing the product over to the operator	18			
8	Adapting the unit to the installation	18			
8.1	Calling up the installer level	18			
8.2	Activating and setting photovoltaic mode	18			
8.3	Reading the input data	19			
8.4	Setting the anti-legionella function	19			
8.5	Selecting the load relief stage	19			
8.6	Setting the minimum temperature	20			
8.7	Setting the fan mode	20			
8.8	Setting the maximum heating time	20			
8.9	Reading the meter status	20			
8.10	Locking the control elements	20			
8.11	Checking the immersion heater	21			
9	Troubleshooting	21			
9.1	Eliminating faults	21			
9.2	Resetting parameters to factory settings	21			

1 Safety

1.1 Intended use

There is a risk of injury or death to the user or others, or of damage to the product and other property in the event of improper use or use for which it is not intended.

The product is intended for hot water generation.

Intended use includes the following:

- observance of accompanying operating, installation and maintenance instructions for the product and any other system components
- installing and setting up the product in accordance with the product and system approval
- compliance with all inspection and maintenance conditions listed in the instructions.

Intended use also covers installation in accordance with the IP code.

Any other use that is not specified in these instructions, or use beyond that specified in this document, shall be considered improper use. Any direct commercial or industrial use is also deemed to be improper.

Caution.

Improper use of any kind is prohibited.

1.2 General safety information

1.2.1 Risk caused by inadequate qualifications

The following work must only be carried out by competent persons who are sufficiently qualified to do so:

- Set-up
- Dismantling
- Installation
- Start-up
- Inspection and maintenance
- Repair
- Decommissioning
- ▶ Proceed in accordance with current technology.

1.2.2 Risk caused by inadequate qualifications for the R290 refrigerant

Any activity that requires the unit to be opened must only be carried out by competent persons who have knowledge about the particular properties and risks of R290 refrigerant.

Specific expert refrigeration knowledge in compliance with the local laws is required when carrying out work on the refrigerant circuit. This also includes specialist knowledge about handling flammable refrigerants, the corresponding tools and the required personal protective equipment.

- ▶ Comply with the corresponding local laws and regulations.

1.2.3 Risk of death from electric shock

There is a risk of death from electric shock if you touch live components.

Before commencing work on the product:

- ▶ Disconnect the product from the power supply by switching off all power supplies at all poles (electrical partition with a contact gap of at least 3 mm, e.g. fuse or circuit breaker).
- ▶ Secure against being switched back on again.
- ▶ Check that there is no voltage.

1.2.4 Risk of death due to lack of safety devices

The basic diagrams included in this document do not show all safety devices required for correct installation.

- ▶ Install the necessary safety devices in the installation.
- ▶ Observe the applicable national and international laws, standards and directives.

1.2.5 Risk of death due to explosive and flammable materials

- ▶ Do not use the product in storage rooms that contain explosive or flammable substances (such as petrol, paper or paint).

1.2.6 Risk of death caused by fire or explosion if there is a leak in the refrigerant circuit

The product contains the combustible refrigerant R290. In the event of a leak, escaping



refrigerant may mix with air to form a flammable atmosphere. There is a risk of fire and explosion.

- ▶ If you are working on the product when it is open, before starting work, use a gas sniffer to ensure that there is no leak.
- ▶ The gas sniffer itself must not be an ignition source. The gas sniffer must be calibrated to R290 refrigerant and set to $\leq 25\%$ of the lower explosive limit.
- ▶ Keep all ignition sources away from the protective zone. In particular, open flames, hot surfaces with temperatures above 370 °C, electrical devices or tools that are not free from electrical sources, static discharges.

1.2.7 Risk of death caused by fire or explosion when removing the refrigerant

The product contains the combustible refrigerant R290. The refrigerant may mix with air to form a flammable atmosphere. There is a risk of fire and explosion.

- ▶ Only carry out the work if you are competent at handling R290 refrigerant.
- ▶ Wear suitable personal protective equipment and bring a fire extinguisher with you.
- ▶ Only use tools and units that are permitted for R290 refrigerant and are in proper working condition.
- ▶ Ensure that no air gets into the refrigerant circuit, into refrigerant-carrying tools or units, or into the refrigerant cylinder.
- ▶ Note that the refrigerant R290 must never be introduced into the sewage system.

1.2.8 Risk of burns, scalds and frostbite due to hot and cold components

There is a risk of burns and frostbite from some components, particularly uninsulated pipelines.

- ▶ Only carry out work on the components once these have reached environmental temperature.

1.2.9 Material damage due to unsuitable installation surface

The installation surface must be even and have sufficient load-bearing capacity to support the operating weight of the product. An

uneven installation surface may cause leaks in the product.

If the installation surface does not have sufficient load-bearing capacity, the product may topple.

There is a risk of death if the connections are subject to leaks.

- ▶ Make sure that the product is positioned flush against the installation surface.
- ▶ Ensure that the installation surface has sufficient load-bearing capacity to bear the operating weight of the product.

1.2.10 Risk of injury due to the heavy weight of the product

The product weighs over 50 kg.

- ▶ Make sure that the product is carried by at least two people.
- ▶ Use suitable transport and lifting equipment, such as the transportation bag supplied.
- ▶ Use suitable personal protective equipment: Gloves, safety footwear, protective goggles, protective helmet.

1.2.11 Risk of material damage caused by frost

- ▶ Do not install the product in rooms prone to frost.

1.2.12 Risk of material damage caused by using an unsuitable tool

- ▶ Use the correct tool.

1.2.13 Risk of material damage caused by water that is too hard

Water that is too hard may impair the system's functionality and cause damage in a short period of time.

- ▶ Ask your local water company about the water hardness.
- ▶ When deciding whether the water used must be softened, follow the national regulations, standards, directives and laws.
- ▶ In the installation and maintenance instructions for the product that your system comprises, you can read the qualities that the water that is used must have.





1.2.14 Risk of damage from corrosion caused by unsuitable room air

Sprays, solvents, chlorinated cleaning agents, paint, adhesives, ammonia compounds, dust or similar substances may lead to corrosion on the product and in the air pipes.

- ▶ Ensure that the air supply is always free of fluorine, chlorine, sulphur, dust, etc.
- ▶ Ensure that no chemical substances are stored at the installation site.
- ▶ Ensure that the air is not routed through an old hearth.
- ▶ If you are installing the product in hairdressing salons, painter's or joiner's workshops, cleaning businesses or similar locations, choose a separate installation room in which an air supply is ensured that is technically free of chemical substances.
- ▶ If the air in the room in which the product is installed contains aggressive vapours or dust, ensure that the product is sealed and protected.

1.2.15 Structural damage due to escaping water

Escaping water can cause damage to the building.

- ▶ Install the hydraulic lines without tension.
- ▶ Use seals.

1.3 Regulations (directives, laws, standards)

- ▶ Observe the national regulations, standards, directives, ordinances and laws.



2 Notes on the documentation

2.1 Observing other applicable documents

- ▶ Always observe all the operating and installation instructions included with the system components.

2.2 Storing documents

- ▶ Pass these instructions and all other applicable documents on to the end user.

2.3 Validity of the instructions

These instructions apply only to:

Unit – article number

aroSTOR VWL B 200/5 UK	0010024440
aroSTOR VWL B 270/5 UK	0010028218
Kit, unvented tank 18L HP Vaillant	0020230777
Temperature and pressure relief valve	0020293791

3 Product description

These products have been tested in accordance with standard EN12897.

3.1 Product design

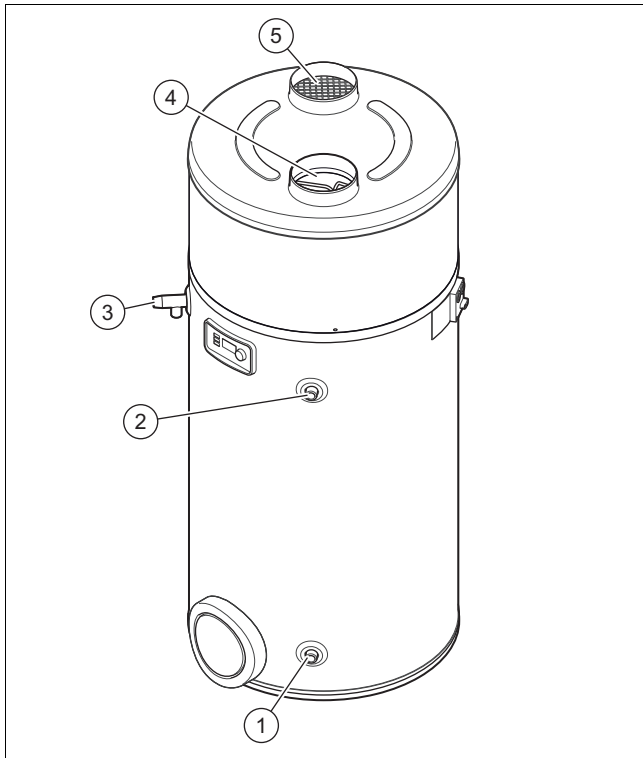

- | | |
|---------------------------------|---|
| 1 Cold water connection | 3 Temperature and pressure relief valve |
| 2 Domestic hot water connection | 4 Air supply |
| | 5 Air removal |

3.2 Operation

The unit includes the following circuit:

- The refrigerant circuit releases heat into the domestic hot water cylinder by means of evaporation, compression, condensation and expansion

3.2.1 Heating mode

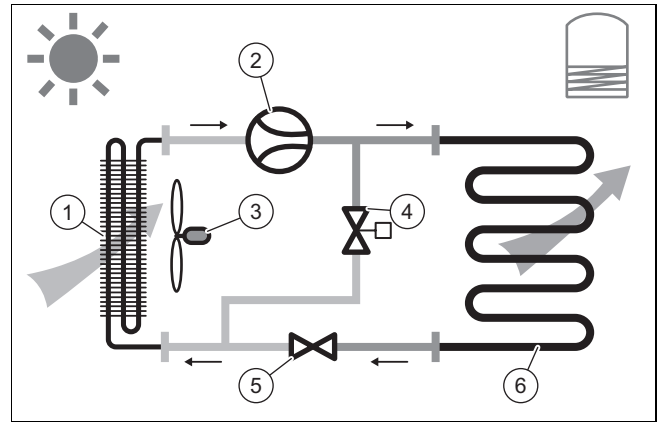

- | | |
|--------------|--------------------------------|
| 1 Evaporator | 4 Defrosting valve |
| 2 Compressor | 5 Thermostatic expansion valve |
| 3 Fan | 6 Condenser |

3.2.2 Defrosting mode

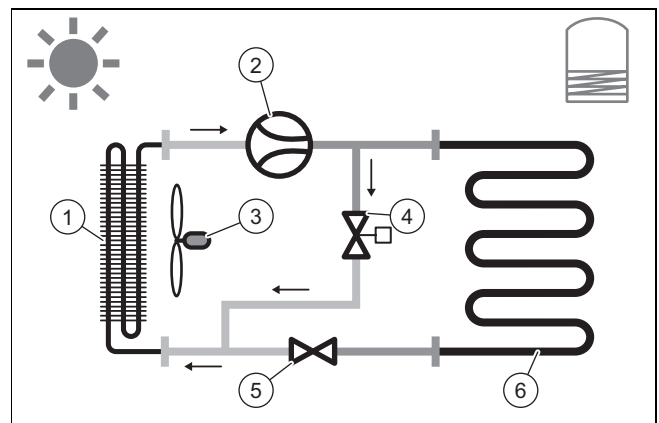

- | | |
|--------------|--------------------------------|
| 1 Evaporator | 4 Defrosting valve |
| 2 Compressor | 5 Thermostatic expansion valve |
| 3 Fan | 6 Condenser |

3.3 Basic system diagram

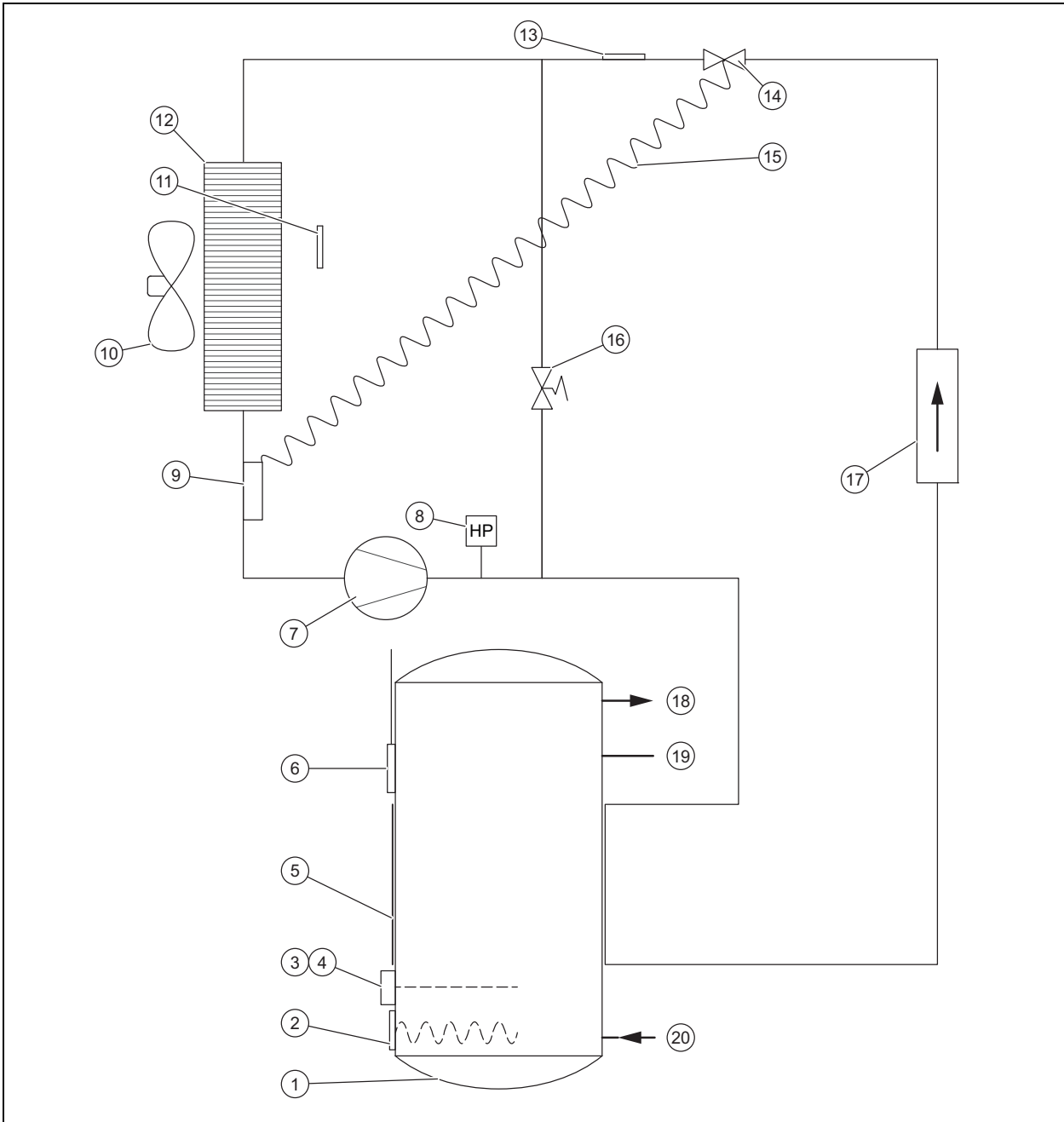

- | | | | |
|----|--|----|--|
| 1 | Domestic hot water cylinder | 11 | Air inlet temperature sensor |
| 2 | Heating coil | 12 | Evaporator |
| 3 | Immersion heater temperature cut-out | 13 | Defrosting sensor |
| 4 | Immersion heater safety cut-out | 14 | Thermostatic expansion valve |
| 5 | External condenser | 15 | Thermostatic expansion valve capillary |
| 6 | Domestic hot water cylinder's temperature sensor | 16 | Defrosting valve |
| 7 | Compressor | 17 | Drainage filter |
| 8 | Pressure switch | 18 | Domestic hot water flow |
| 9 | Sensor head thermostatic expansion valve | 19 | Temperature and pressure relief valve |
| 10 | Fan | 20 | Cold water connection |

3.4 Type designation and serial number

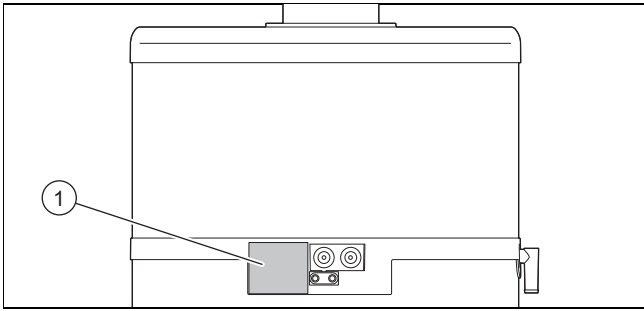

The type designation and serial number are on the data plate (1).

3.5 CE marking



The CE marking shows that the products comply with the basic requirements of the applicable directives as stated on the declaration of conformity.

The declaration of conformity can be viewed at the manufacturer's site.

3.6 Hot Water Association

Vaillant is a full member of the Hot Water Association and promotes the scheme in association with its cylinder range. Details are available on the web site www.vaillant.co.uk



The HWA Charter's Code of Practice requires that all members adhere to the following:

- To supply fit for purpose products clearly and honestly described
- To supply products that meet, or exceed appropriate standards and building and water regulations
- To provide pre and post sales technical support
- To provide clear and concise warranty details to customers

3.7 Benchmark

Vaillant is a licensed member of the Benchmark Scheme.

Benchmark places responsibilities on both manufacturers and installers. The purpose is to ensure that customers are provided with the correct equipment for their needs, that it is installed, commissioned and serviced in accordance with the manufacturer's instructions by a competent person approved at the time by the Health and Safety Executive and that it meets the requirements of the appropriate Building Regulations. The Benchmark Checklist can be used to demonstrate compliance with Building Regulations and should be provided to the customer for future reference.

Installers are required to carry out installation, commissioning and servicing work in accordance with the Benchmark Code of Practice which is available from the Heating and

Hotwater Industry Council who manage and promote the Scheme.

Benchmark is managed and promoted by the Heating and Hotwater Industry Council.



For more information visit www.benchmark.org.uk.

4 Set-up

4.1 Transporting the product to the installation site

When being transported, the product must ideally be in a vertical position. It must only be placed in a horizontal position at the front, as specified on the packaging, if the height of the vehicle is lower than the height of the product.

4.2 Carrying the product

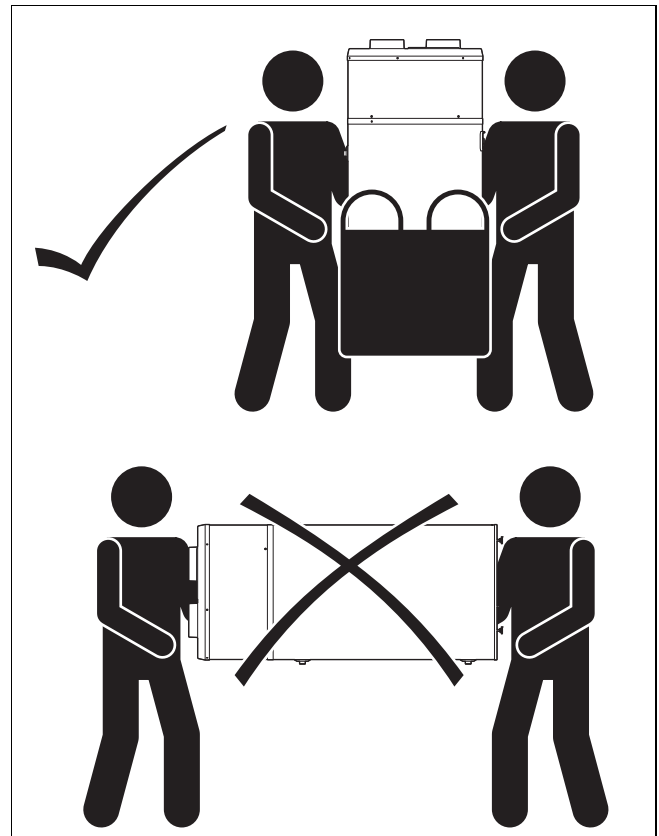

Caution.

Risk of material damage caused by incorrect handling.

The product's upper covering hood is not designed for loading and must not be used for storage.

- ▶ Do not lift the product by the top covering hood when transporting it.



Warning.

Risk of injury from lifting a heavy weight.

Lifting weights that are too heavy may cause injury to the spine, for example.

- ▶ When transporting the product, lift it with the help of a second person.
- ▶ Observe the product weight stated in the technical data.
- ▶ When transporting heavy loads, observe the applicable directives and regulations.

1. Transport the product to the installation site using a forklift truck or pallet truck.
2. Transport the product in the upright position only.

Condition: Transport the product to the final installation site in the transportation bag supplied.

- ▶ Fully open out the transportation bag and lay it on the ground.
- ▶ Using a rocking and turning motion, "walk" the product to the centre of the transportation bag.
- ▶ Lift up the handles of the transportation bag to draw in the sides of the transportation bag.



Note

Keep the transportation bag away from children in order to prevent the risk of suffocation.

Condition: Transport the product to the final installation site using a hand truck.

- ▶ Secure the product using a strap.
- ▶ In order to avoid scratches and damage, protect the sides of the product that come into contact with the hand truck.

4.3 Unpacking the product

1. Remove the straps.
2. Pull the cardboard box up and off.
3. Remove the two cardboard rings from around the product.
4. Remove the cardboard box transport protection at the compressor, as described on the sticker on the covering hood.
5. Remove the protective film.
6. Remove the accessory pack from the transportation bag.
7. Remove the screw that is securing the product to the pallet from the underside of the pallet without tilting the product.
8. Ensure that nobody holds up or leans against the product.

4.4 Checking the scope of delivery

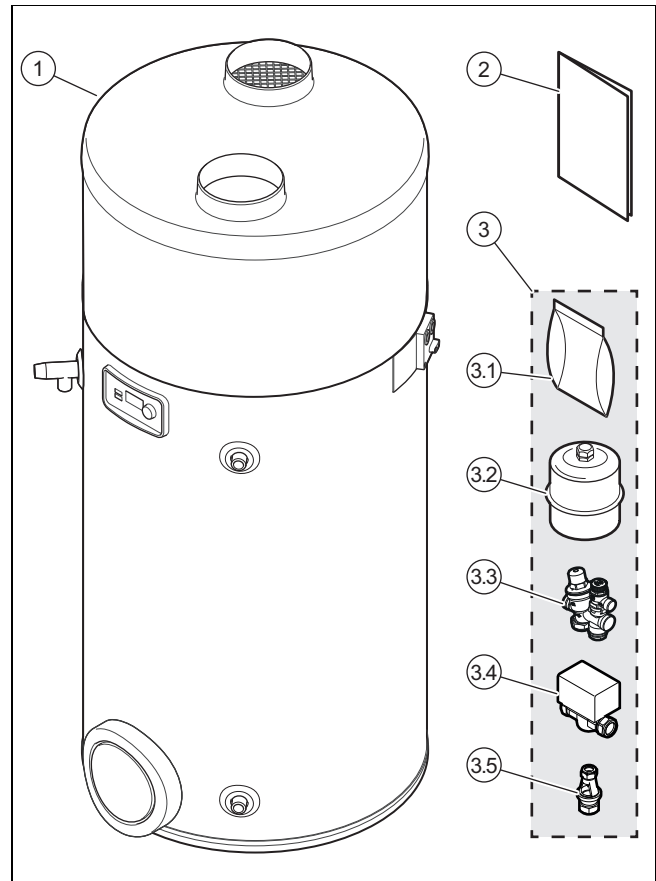

- ▶ Check that the scope of delivery is complete.

Reference point	Designation
1	Domestic hot water cylinder and temperature and pressure relief valve
2	Enclosed documentation
3	Kit, unvented tank 18L HP Vaillant
3.1	Bag with accessories
3.2	Expansion vessel
3.3	Safety assembly
3.4	2-port diverter valve (not used)
3.5	Tundish with retainer

4.5 Product dimensions and connection dimensions

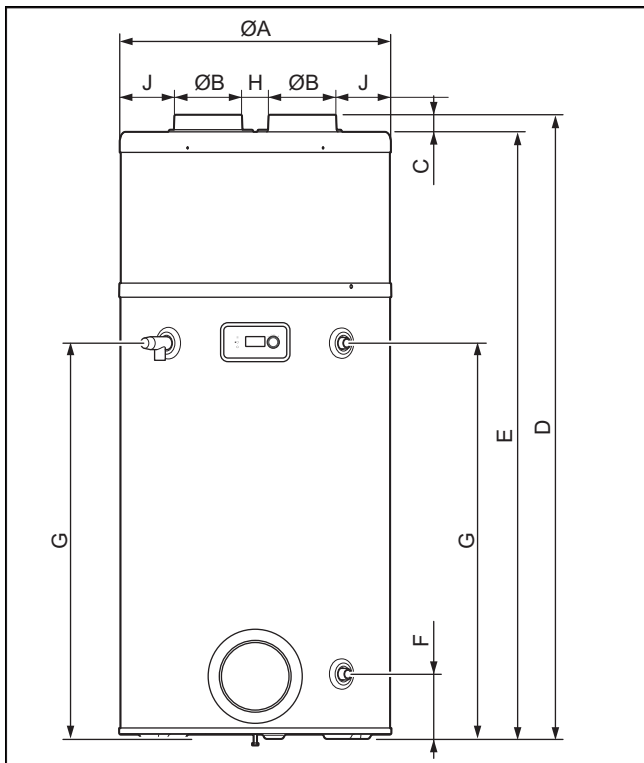

Unit dimensions and connection dimensions

	aroSTOR VWL B 200/5 UK	aroSTOR VWL B 270/5 UK
A	634 mm	634 mm
B	158 mm	158 mm
C	40 mm	40 mm
D	1,458 mm	1,783 mm
E	1,418 mm	1,743 mm
F	151 mm	151 mm
G	924 mm	1,249 mm
H	134 mm	134 mm
J	92 mm	92 mm

4.6 Requirements for the installation site

- ▶ Select a dry room that is frost-proof throughout and in which the maximum installation height is not exceeded and the environmental temperature is neither above nor below the permitted range.
- ▶ If the product is operated as room-sealed, it must not be situated within 500 m of any coastline.
- ▶ Do not place the product in the vicinity of another unit which could damage it (e.g. next to a unit which releases vapour or grease), or in a room with a high level of exposure to dust or in a corrosive environment.
- ▶ Set up the product with sufficient clearance to be able to carry out maintenance work and repairs.
- ▶ When selecting the installation site, you must take into consideration that when the heat pump is in operation, it will transfer vibrations to the floor and the nearby walls.
- ▶ In order to avoid noise disturbance, do not install the product near bedrooms.
- ▶ We recommend maintaining the following clearance to allow for maintenance:

- Around the product: At least 25 mm.
- Top and front: At least 300 mm.

4.7 Removing/installing the protective cover

4.7.1 Removing the covering hood

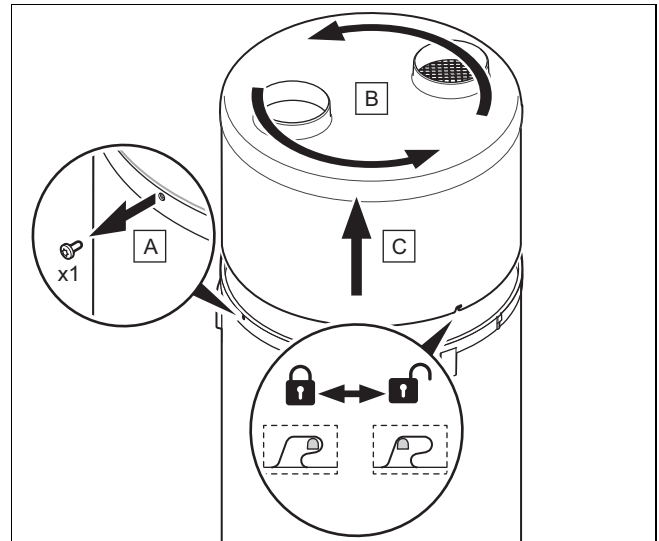

1. Use a Torx screwdriver (Tx20) to remove the Torx screw (A).
2. Turn the covering hood (B) anti-clockwise to loosen it from the positioning lugs.
3. Slightly lift the covering hood (C) and remove it.

4.7.2 Installing the covering hood

1. Place the covering hood on the cylinder.
2. Turn the covering hood clockwise to position the positioning lugs and align the screw hole.
3. Use a Torx screwdriver (Tx20) to tighten the screw.

5 Installation



Caution.

Risk of material damage due to heat transfer during soldering.

- ▶ Do not carry out any welding work in the area of the product's connectors.
- ▶ Before any welding work, insulate the water-carrying pipes on the product's outlet and the installation.



Danger!

Risk of scalding and/or damage due to incorrect installation leading to escaping water.

Mechanical stresses in the connection pipes may lead to leaks.

- ▶ Ensure that there is no mechanical stress when installing the connection pipes.



Caution.

Risk of damage in the pipelines due to residue.

Residue from pipelines, such as welding beads, scale, hemp, putty, rust and coarse dirt, may be deposited in the product and cause malfunctions.

- ▶ Flush the pipelines thoroughly before connecting to the product in order to remove any possible residue.



Note

To comply with the requirements of the G3 construction regulation, this product is fitted with a temperature and pressure relief valve at the factory in accordance with standard BS EN 1490. Diversions from a non-purged cylinder must be guided to a point at which it is visible without putting anybody in the building in danger. The tundish and the drain hose must be installed in accordance with the requirements of the approved document Building Regulation G3 (England and Wales), from part P for Northern Ireland and standard 4.9 for Scotland.

5.1 Installing the air supply and air exhaust

5.1.1 Selecting air duct systems



Caution.

Risk of material damage caused by incorrect installation.

- ▶ Do not connect the product to internal extract air ducts, including those of bathrooms, shower rooms and kitchen extractors.

1. Use only commercially available, insulated air ducts with suitable heat insulation, to prevent energy loss and condensation from forming on the air ducts.

Maximum length of the air pipes L1 + L2 (L1 = air intake pipe; L2 = air outlet pipe)	
Standard value	L1 + L2
Condition: Flexible pipes	10 m Note In addition to the total length, two 90° elbows can be added.
Condition: Fixed pipes	20 m Note In addition to the total length, two 90° elbows can be added.



Note

In an installation with rigid pipes, elbows, attachments and mesh create additional pressure losses in the air duct system that may correspond to five metres of straight pipe length per element. Make sure that the maximum permitted lengths are not exceeded with the elements used.

2. Protection devices must be installed at the openings of the air ducts to prevent water or foreign bodies from penetrating the pipelines (protective grille for vertical walls, roof terminals).
3. Always protect the product against modification or intervention in order to prevent water or foreign substances from penetrating as this may damage the pipes or other components.

5.1.2 Installing the complete pipe system

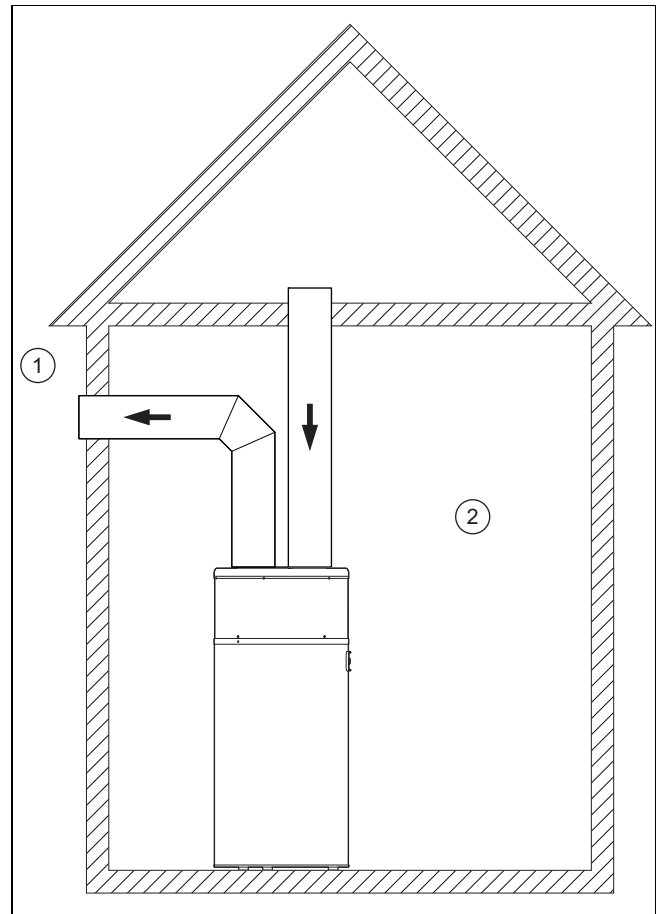

1 External area 2 Internal area (heated or not heated)

The air inlet and outlet are located in the external area.

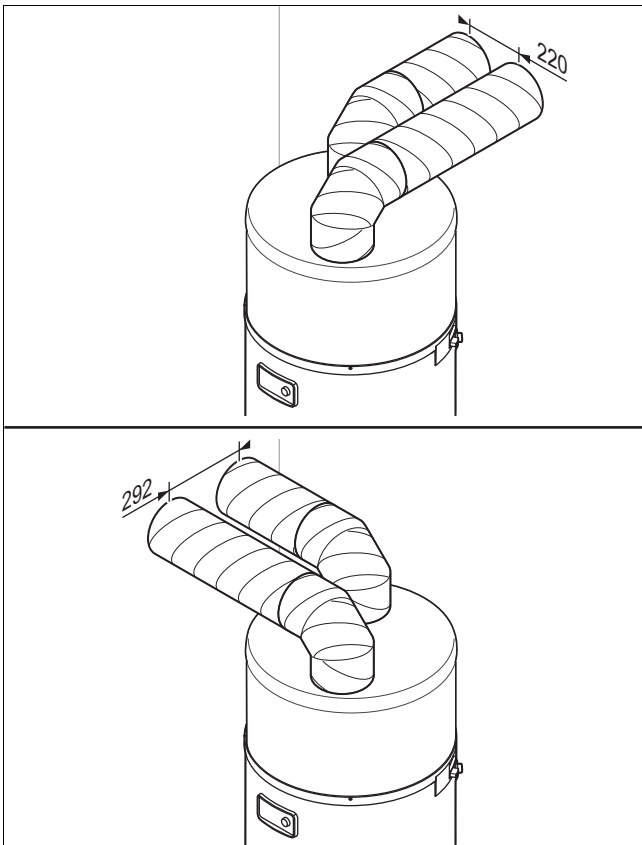

This installation type is particularly suitable for small rooms (supply or store room, etc.).

This configuration prevents a room from being cooled and does not impair ventilation.

- ▶ In order to prevent leak air from being extracted by recirculation, maintain a clearance between the ends of the air pipes.
 - Clearance: ≥ 220 mm

5.1.3 Installing the partial pipe system

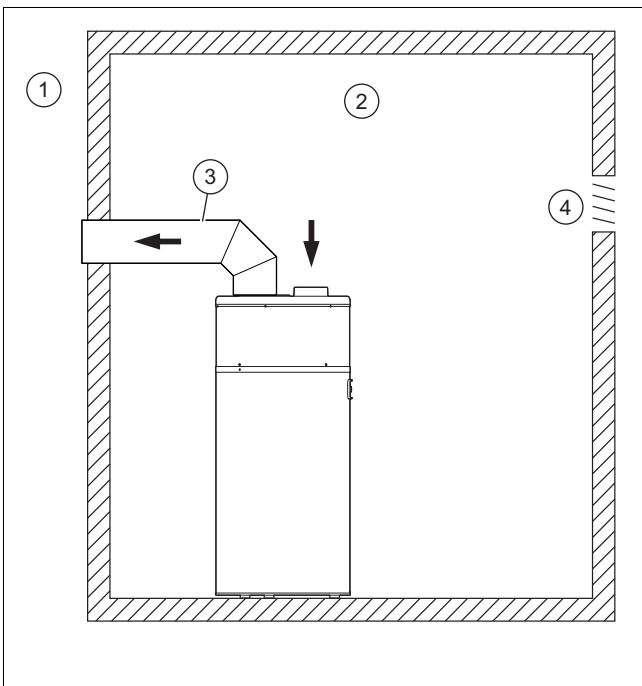

- | | | | |
|---|--------------------------------------|---|--|
| 1 | External area | 3 | Heat-insulated pipe (diameter ≥ 160 mm) |
| 2 | Internal area (heated or not heated) | 4 | Ventilation |

The hot air is drawn into the room and the cold air is released outside.

With this installation type, the room is used as an energy collector. The room is cooled by outdoor air that flows in via the ventilation openings.

- Room volume at installation site: ≥ 20 m³



Caution.

Risk of material damage due to condensation forming on the outside of the pipe.

The difference in temperature between the air flowing through the pipe and the air in the installation room can cause condensation to form on the outside surface of the pipe.

- ▶ Use air pipes with suitable heat insulation.

- ▶ Avoid negative pressure in the installation room in order to ensure that air is not extracted from surrounding heated rooms.
- ▶ Check whether the existing ventilation can compensate for the withdrawn air flow.
 - Air flow: ≥ 400 m³/h
- ▶ Add the air flow that is required for normal ventilation of the installation room to the withdrawn air.
- ▶ If required, adjust the ventilation.

5.1.4 Installing without a pipework system

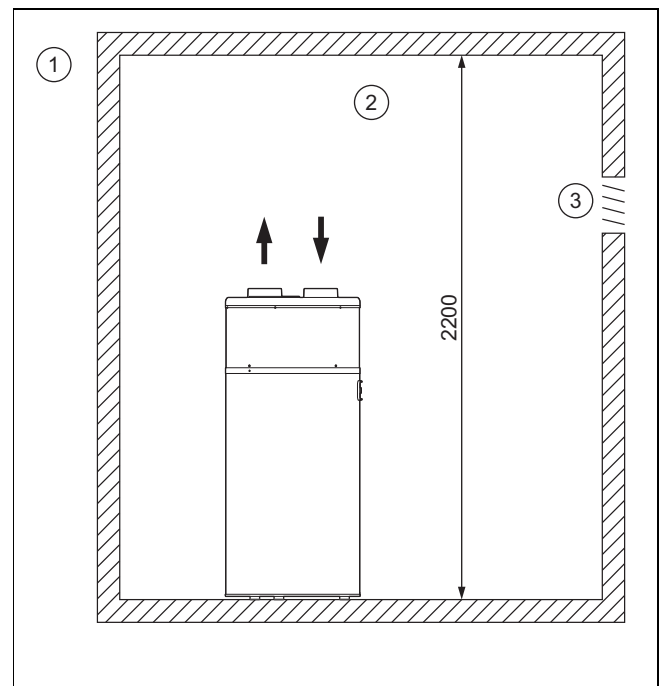

- | | | | |
|---|--------------------------------------|---|-------------|
| 1 | External area | 3 | Ventilation |
| 2 | Internal area (heated or not heated) | | |

The air is drawn into and conducted away from the same room.

With this installation type, the room is used as an energy collector. The room is cooled by the hot and cold air that the product emits.



Caution.

Risk of material damage caused by frost inside the house

Even at outdoor temperatures above 0 °C, there is a risk of frost in the installation room.

- ▶ Use suitable heat insulation to protect pipelines and other elements in the installation room that are sensitive to cold.

To prevent the cold air emitted by the product from re-entering it, maintain the minimum clearance between the upper side of the product and the ceiling.

- Room volume at installation site: $\geq 20 \text{ m}^3$
- Minimum room height: $\geq 2.20 \text{ m}$

5.2 Installing the water connections

5.2.1 Water-side connection



Caution.

Risk of damage caused by heat transfer when welding.

The heat that is transferred during welding may damage the cylinder and its components as well as the connection seals.

- ▶ Protect the product and its components.
- ▶ Do not weld the connection pieces if these have been screwed into the pipe fittings.



Caution.

Risk of material damage by drilling through the product.

The product may be damaged by drilling work.

- ▶ Do not drill through the product.



Caution.

Risk of material damage to the cylinder.

If an unvented hot water cylinder is fitted at a high level (eg, loft space), potential damage to the cylinder may occur if the correct method of draining is not followed.

- ▶ In certain circumstances and at the discretion of the installer, install a WRAS approved automatic air vent on the hot water outlet at the highest point.

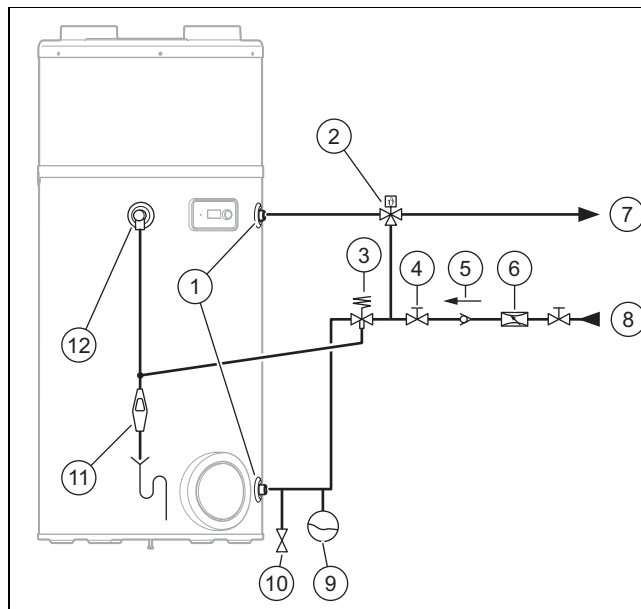

1	Dielectric connection	7	Domestic hot water flow
2	Thermostatic mixer tap	8	Cold water pipe
3	Safety assembly	9	Expansion vessel
4	Stopcock	10	Drain valve
5	Non-return valve	11	Tundish
6	Pressure reducer	12	Temperature and pressure relief valve

5.2.2 Hydraulics installation

- ▶ Use flat seals.
 - Torque: $\leq 20 \text{ Nm}$

5.2.3 Connecting the cylinder

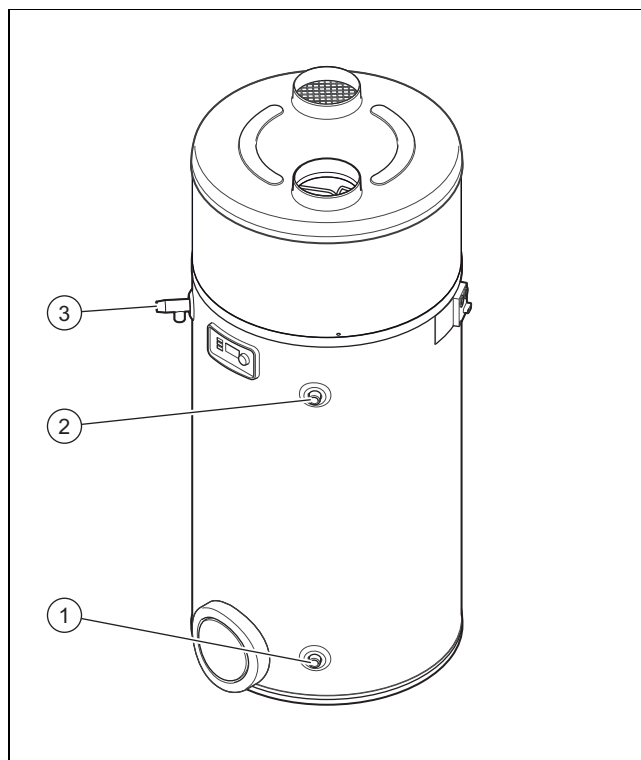

1. Ensure that the distance between the heat generator and the product is as small as possible in order to prevent heat losses.
2. Connect the cold water pipe (1).

- Minimum diameter of the copper pipe: ≥ 22 mm
3. Connect the domestic hot water flow to (2).
 - Minimum diameter of the copper pipe: ≥ 22 mm
 4. Carry out a leak-tightness check on all connections, including the expansion relief valve (3).

5.2.4 Installing the drain valve

A drain valve must be supplied by the customer.

Install the drain valve at the lowest point of the cold water supply pipe.

5.2.5 Installing the safety assembly



Caution.

Excessive pressure in the domestic hot water cylinder

Excessive pressure in the domestic hot water cylinder may cause the cylinder to burst.

- ▶ Ensure that the expansion relief valves are not blocked.
- ▶ Ensure that there is no isolation valve between the safety group and the cylinder.

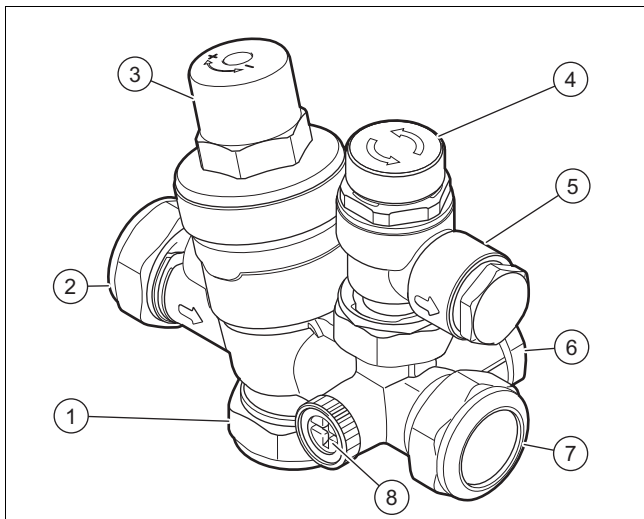

- | | | | |
|---|---|---|--|
| 1 | Balanced cold water | 6 | Connection for the expansion vessel (22 mm) |
| 2 | Cold water inlet (22 mm) | 7 | Flow of the cold water supply to the cylinder |
| 3 | Pressure reducer | 8 | Connecting a manometer (optional, not included in the scope of delivery) |
| 4 | Expansion relief valve | | |
| 5 | Outlet for the expansion relief valve (15 mm) | | |

1. Before installation, flush the pipes in order to clear any contamination and prevent the build up of dirt.
2. Install the safety assembly horizontally and install the expansion relief valve so that it is facing upwards.
3. Note the flow direction, which is specified by an arrow.
4. Install a pipe between the safety assembly's connection and the temperature and pressure relief valve. Use a T-piece for this. The pipe system must continuously slope outwards, must be visible and must be protected against frost. There must be no risk of injury to persons.

- Diameter of the pipe: 15 mm
 - Length of the hose between the temperature and pressure relief valve and the expansion relief valve: ≤ 600 mm
5. Connect the cold water inlet to the safety assembly.
 - Diameter of the cold water supply pipe: ≥ 22 mm

5.2.6 Installing an expansion vessel

1. Install the expansion vessel close to the product.
2. Use the enclosed flexible hose to connect an expansion vessel to the product's cold water inlet unit.
3. Do not install any isolators between the expansion vessel and the safety assembly.
4. Do not install a separator between the product and the cold water inlet unit.
5. Install the expansion vessel higher than the product in order to not have to drain the product during maintenance or when replacing the expansion vessel.
6. Check the pre-charge pressure of the diaphragm in the expansion vessel before you fill the product.
 - ≥ 0.3 MPa (≥ 3.0 bar)

5.2.7 Connecting the condensate discharge pipe

1. Observe the locally applicable rules and regulations on condensate discharge.

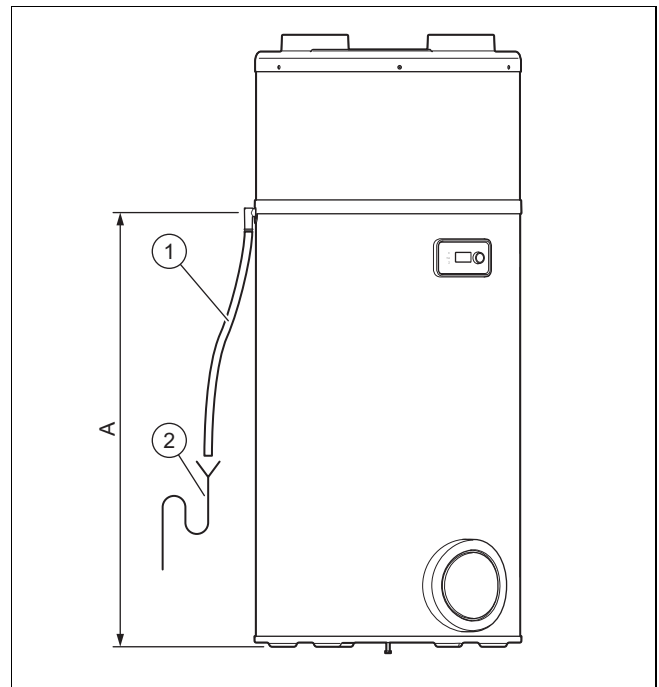

2. Connect the condensate discharge pipe (1) to a pre-installed drain siphon (2).

Cylinder volume	Dimensions (A)
aroSTOR VWL B 200/5 UK	1047 mm
aroSTOR VWL B 270/5 UK	1367 mm

3. Route the condensate discharge pipe with a downward gradient and without any kinks.
4. Fill the drain siphon with water.
5. Leave a small clearance between the end of the condensate discharge pipe and the drain siphon.
6. Ensure that the connection between the condensate discharge pipe and the drain siphon is not air-tight.

7. Check whether the condensate drains off without any problems.

5.2.8 Installing a drain pipe

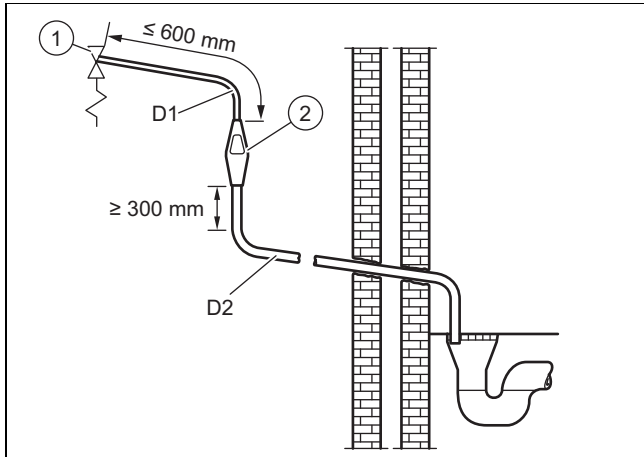

1 Temperature and pressure relief valve

2 Tundish

The drain connections of the temperature and pressure relief valve and the expansion relief valve must be connected to the supplied tundish via 15-mm-thick copper pipes. The tundish must be installed vertically, as close to the cylinder as possible and with a maximum distance of 600 mm from the connection of the temperature and pressure relief valve. It must be installed in the same room as the cylinder, but at a sufficient distance from electrical components. The drain pipes from the temperature and pressure relief valve and from the expansion relief valve can be connected above the tundish using a T-piece. The drain pipe from the 22 mm connection of the tundish must consist of copper pipes with a diameter of at least 22 mm and be connected to a safe and visible drainage point. The vertical section of pipe beneath the tundish must be at least 300 mm long before any bends or diversions in the line. If the total resistance of the drain pipework exceeds the values in the following table, you must increase the diameter of the pipework. When installing the drain pipework, comply with the standards, directives and laws that are applicable in your country.

Size of the outlet valve	Minimum diameter of the drain pipe D1	Minimum diameter of the drain pipe from the tundish D2	Maximum permissible resistance, information on the length of a straight pipe	Resistance per elbow or bend
1/2"	15 mm	22 mm	9 m	0.8 m
		28 mm	≤ 18 m	1.0 m
		35 mm	≤ 27 m	1.4 m
3/4"	22 mm	28 mm	≤ 9 m	1.0 m
		35 mm	≤ 18 m	1.4 m
		42 mm	≤ 27 m	1.7 m
1"	28 mm	35 mm	≤ 9 m	1.4 m
		42 mm	≤ 18 m	1.7 m
		54 mm	≤ 27 m	2.3 m

Sample calculation

The following example corresponds to a temperature and pressure relief valve G1/2 with a drain pipe (D2) with four 22 mm elbows and a length of 7 m from the tundish to the drain-

age point. According to the table, the maximum permissible resistance for a straight length of a 22-mm-thick copper discharge pipe (D2) of a thermal expansion relief valve G1/2 is 9.0 m. The resistance of the four 22 mm elbows, which are each 0.8 m in length, must be subtracted from this, i.e. a total of 3.2 m. The maximum permitted length is accordingly 5.8 m and is therefore below the current length of 7 m. The calculation must therefore be performed using the second largest size. The maximum permissible resistance for a straight length of a 28-mm-thick pipe (D2) of a thermal expansion relief valve G1/2 is 18 m. The resistance of the four 28 mm elbows, which are each 1.0 m in length, must be subtracted from this, i.e. a total of 4.0 m. The maximum permitted length is accordingly 14 m. As the current length is 7 m, a 28 mm copper pipe (D2) should be selected.

A suitable location for the drain pipe terminal is, for example, beneath a fixed mesh above the odour trap in a soakaway with a siphon. Low drain pipework, for example up to 100 mm above external surfaces (car parks, meadows, etc.) can be used provided that it is protected by a wire cage or something similar to prevent children from coming into contact with the waste water and provided that the system is not visible. Do not install any valves or stopcocks on the drain pipework.

Make sure that the drain pipe from the tundish to the drain has a constant downward gradient of at least 1:200.



Note

The temperature and pressure relief valve is pre-installed with a seal. If this seal is displaced, there is a risk that it will tear. In this case, replace the defective seal with a suitable seal.

5.2.9 Drainage at great heights

Drainage at a great height is permissible as long as there is no danger to persons in the vicinity of the drain. There are a few points to consider here:

- The position of the windows and other openings.
- The probability of prams being under the drain opening.
- Ensure that all materials onto which the waste water is discharged are suitable for high temperatures.

5.2.10 thermostatic valve

A thermostatic mixing valve may be required in order to limit the domestic hot water outlet temperature.

- ▶ Install the thermostatic valve in accordance with the manufacturer's specifications.
- ▶ Ensure that no part of the safety assembly is insulated and that the mixing valve is therefore connected in accordance with the cold water inlet's safety assembly.

5.2.11 Insulating lines

We recommend providing the domestic hot water pipe on the product's outlet with heat insulation in order to reduce the energy demand for the domestic hot water generation. Furthermore, all other exposed lines, from the temperature and pressure relief valve to the tundish, the flow and return of the cylinder heat exchanger, and the cold water supply lines, should also be provided with heat insulation.

5.3 Electrical installation

Only qualified electricians are allowed to carry out the electrical installation.



Danger! **Risk of death from electric shock!**

The mains connection terminals L and N remain live even if the product is switched off.

- ▶ Switch off the power supply.
- ▶ Secure the power supply against being switched on again.



Danger! **Risk of death from electric shock!**

The condensers are still charged even hours after the power supply was disconnected.

- ▶ Wait until the condensers have discharged.

The product's power supply must not be interrupted by a timer.

5.3.1 Electrical connection

1. Ensure that the power supply complies with the regulations for the country of installation and the IEE Wiring Regulations.
2. Install a permanent isolator that fulfils the conditions of overvoltage category III.
3. Protect the product by installing the following elements.
 - Electrical partition, 8 A, with a contact gap of at least 3 mm.
 - Residual-current circuit breaker, 30 mA, to protect the electrical partition, 8 A.
4. If the power supply cable is damaged, it must be replaced by a competent person or electrician.

5.3.2 Carrying out the wiring

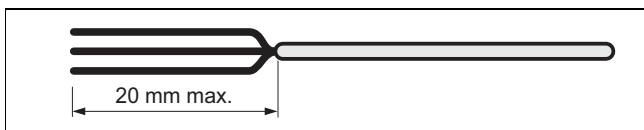

1. Guide the extra-low and low-voltage cables through different grommets on the rear of the product.
2. Ensure that the inner conductors' insulation is not damaged when stripping the outer sheathing.
3. Remove max. 20 mm of insulation from the cables.



Note
If cables are stripped by more than 20 mm, you must secure them using cable ties.

4. Fit the stripped ends of the conductors with crimp pin terminals to ensure a secure connection that is free from loose strands and to thus prevent short circuits.

5.3.3 Connecting the cable for low-tariff or high-tariff load relief



Note
The PV function and high-/low-tariff mode cannot be used in parallel as they use the same contacts.

1. In order to keep the product's operating times as low as possible during high-tariff periods of the power supply (where applicable), connect the electricity meter's control contact.

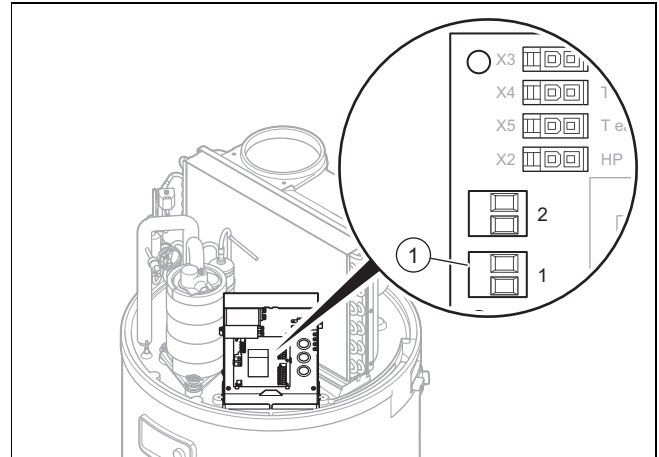

2. Remove the protective cover. (→ Page 10)
3. Remove the black protective cover from the PCB.
4. Remove the red bridge from the energy supply company's connection terminal **(1)** (ESCO contact).
5. Guide the cable through the grommet on the rear of the product and through the grommet on the rear of the electronics box.



Note
Ensure that the grommet is slit open as little as possible to prevent air escaping while the product is in operation.

6. Use the plug **(1)** to establish the connection to the electricity meter's control contact.
 - Twin-core cable: 0.75 mm²
7. Inform the end user if the product is controlled via the low-tariff contact, so that any programming of operating times does not conflict with the high- and low-tariff periods.

5.3.4 Controlling the fan externally

Condition: Installing a partial pipe system

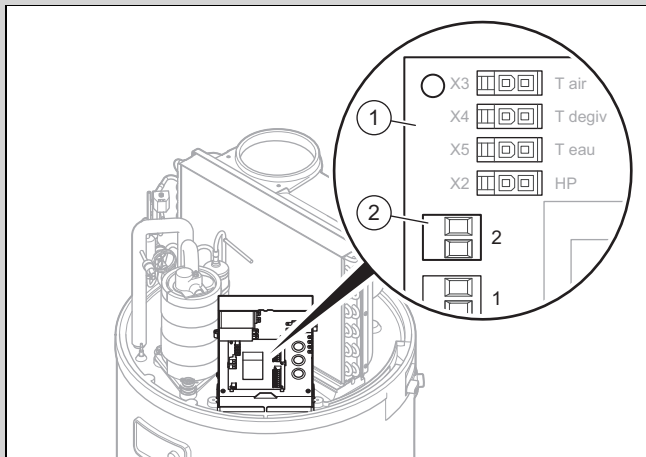

- ▶ If you want to keep a room aerated permanently, even when the product is switched off, you can connect the contact of the external fan control system (humidistat).



Caution.

Risk of material damage caused by incorrect handling.

Only external control contacts are compatible.

- ▶ Only connect the external control contacts to potential-free contacts.
- ▶ In particular, do not connect any live cables.

- ▶ Remove the covering hood. (→ Page 10)
- ▶ Remove the black protective cover from the PCB.
- ▶ Guide the cable through the grommet on the rear of the product and through the grommet on the rear of the electronics box.
- ▶ Connect the humidistat cable to the plug (2) on the PCB (1).
 - ◀ Contact opened: Fan not running
 - ◀ Contact closed: Fan running
- ▶ In the menu, set the "Fan with external control" mode to **FAN MODE 3**.

5.3.5 Connecting the photovoltaic installation



Note

The PV function and high-/low-tariff mode cannot be used in parallel as they use the same contacts.

Condition: Existing photovoltaic installation

This function can make use of the self-sufficiency optimised by the photovoltaic installation to supply the heat pump and the immersion heater and to heat up the water in the cylinder.

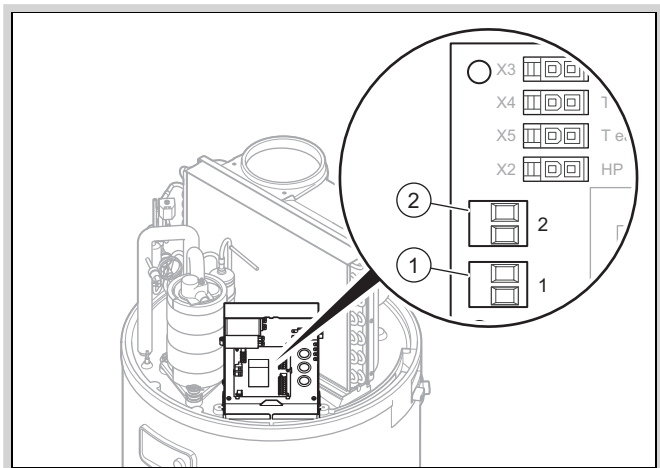

1 Connection terminal 1 2 Connection terminal 2



Caution.

Risk of material damage caused by incorrect handling.

Only external control contacts are compatible.

- ▶ Only connect the external control contacts to potential-free contacts.
- ▶ In particular, do not connect any live cables.

- ▶ Remove the covering hood. (→ Page 10)
- ▶ Remove the black protective cover from the PCB.
- ▶ Connect the cable for the photovoltaic installation to the connection terminal (1) on the PCB.
- ▶ If your photovoltaic installation's control has two control contacts, connect it to the photovoltaic installation at connection terminal (1) and (2) on the PCB; see "Electronics box wiring diagram" in the appendix.
 - Connection terminal (1): Lower level of electrical energy generated by the photovoltaic installation.
 - Connection terminal (2): Upper level of electrical energy generated by the photovoltaic installation.

6 Start-up

6.1 Checking and preparing the cold water supply

- ▶ To guarantee that the product operates safely and to a satisfactory standard, ensure that the water supply meets the following criteria:
 - Minimum flow pressure: 150 kPa (1,500 mbar)
 - Maximum inlet supply pressure: 1,200 kPa (12,000 mbar)
 - Minimum water flow: 15 l/min
 - Maximum chlorine content: 250 mg/l
 - Maximum water hardness: 200 mg/l
- ▶ Ensure that the product's cold water supply comes directly from the cold water network downstream of the main stopcock.
- ▶ Ensure that the cold water supply line has an internal diameter of at least 19 mm, and comply with the requirements of the water regulations for supplying hygienically safe potable water.

If required, precautions can be taken to minimise the effects of the water hardness, for example by installing a water conditioner or a water softener. These devices must be installed in areas with hard water, in which high water cylinder temperatures above 60 °C are required, particularly at a water hardness above 200 ppm. If the product needs to be descaled, this must be carried out by a competent person.

6.2 Filling the domestic hot water circuit



Note

The cylinder must always be filled with water before the heating coil is activated. Otherwise, the component will be damaged and the guarantee will be voided.

1. Disconnect the product from the power grid.
2. Open the highest domestic hot water draw-off point in the installation.
3. Open the stopcock upstream of the safety assembly on the cold water inlet.
4. Fill the domestic hot water cylinder until water escapes at the highest draw-off point.
5. Close the domestic hot water draw-off point.

6.3 Switching on the product

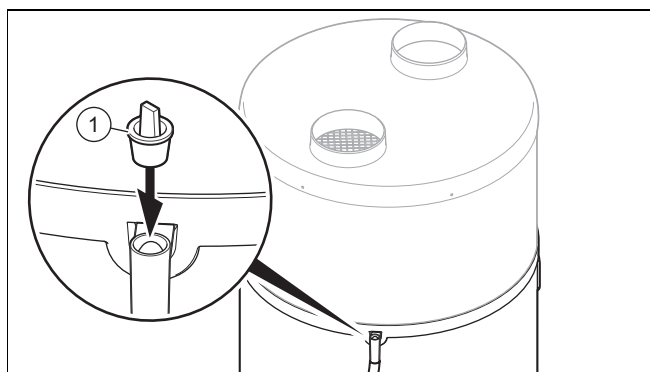

1. Before starting up the product, ensure that the plugs **(1)** have been removed from the condensate discharge connection.
2. Ensure that the stopcock upstream of the safety assembly at the cold water inlet is open.
3. Before switching on the power supply, ensure that the domestic hot water cylinder is full.
4. Ensure that the product has been connected to the power supply.
5. Press the product's on/off button.
 - ◁ The display switches on.
 - ◁ A green LED lights up on the display.
 - ◁ The background lighting on the display flashes and prompts you to set the language.
 - Turn the rotary knob to set the language. Press the rotary knob to confirm the selection.
 - ◁ The product only offers you the language selection when it is switched on for the first time. However, you have the option to change the language setting, → Operating instructions.
 - ◁ The heat pump only starts when the cold water temperature is below the set water temperature and when, according to the operating programme, the switch-on time corresponds to the heat-up time and heating is permitted by the electricity tariff.

- ◁ When the heat pump is running, there is an air flow at the air inlet and outlet.



Note

After the initial start-up, depending on the air intake temperature and cold water temperature, the heat pump requires 5 to 12 hours to reach a temperature of 55 °C.



Note

The thermodynamic water heater operates with the heat pump as priority if the temperature of the intake air is within a range between -7 °C and +45 °C. Outside of this temperature range, the domestic hot water is only generated via the electric back-up heater.

7 Handing the product over to the operator

- ▶ Explain to the operator how the safety devices work and where they are located.
- ▶ Inform the operator how to handle the product.
- ▶ In particular, draw attention to the safety information which the operator must follow.
- ▶ Inform the operator of the necessity to have the product maintained according to the specified intervals.
- ▶ Pass all of the instructions and documentation for the product to the operator for safe-keeping.
- ▶ Inform the operator about measures taken concerning the air pipe and inform them that they must not make any changes.

8 Adapting the unit to the installation

8.1 Calling up the installer level

1. Press the menu button.
2. Turn the rotary knob until the **INST.MENU** menu appears in the display.
3. Hold down the clock button and the menu button for three seconds.
 - ◁ The first menu item of the installer level **PV MODE** is displayed.

8.2 Activating and setting photovoltaic mode

Condition: Existing photovoltaic installation

- ▶ If the control for the photovoltaic installation is connected to plug no. 1 and no. 2 on the product's PCB, you must activate **PV MODE**.
 - ◁ The electrical energy generated is stored in the form of domestic hot water. You can set two efficiency levels for the photovoltaic installation.
 - ◁ **PV ECO** = Low level of photovoltaic power generation. The heat pump generates an increased domestic hot water temperature. The increased domestic hot water temperature must be between the normal domestic hot water temperature and 60 °C.
 - Factory setting: 60 °C

- ◁ **PV MAX** = High level of photovoltaic power generation. The heat pump and the immersion heater generate an increased domestic hot water temperature. The increased domestic hot water temperature must be between the domestic hot water temperature of the **PV ECO** mode and 65 °C.

- Factory setting: 65 °C

- ▶ Turn the rotary knob to set the mode. **INST.MENU PV MODE**
 - ◁ You can select which function has higher priority (photovoltaic mode or frost protection/eco mode)
- ▶ Select **YES**.
- ▶ Press the rotary knob to confirm the selection.
- ▶ Press the menu button.
- ▶ Set the required domestic hot water temperature.
- ▶ Turn the rotary knob to set the priority. **INST.MENU → PV MODE → PRIORITY**.
 - ◁ **YES** : The signals from connection plugs no. 1 and no. 2 have priority over the frost protection and eco mode.
 - ◁ **no** : Frost protection and eco mode have priority over the signals from connection plugs no. 1 and no. 2.



Note

When photovoltaic mode has the higher priority, domestic hot water is also heated during periods that have not been set (e.g. holiday mode and outside of programmed time periods).

If you only want to heat the domestic hot water during the permitted time period, set the priority to **no**.

- ▶ Press the rotary knob to confirm the selection.
 - ◁ The immersion heater is supplied with electricity in order to use the energy from the photovoltaic installation.
 - ◁ When the fan mode is activated (**FAN MODE**), option 3 can no longer be selected.
 - ◁ The **SHED DING** function is not available.
- ▶ Press the menu button to return to the original display.

8.3 Reading the input data

1. If you want to read the product's input data, you must select this menu. **DI SPLAY → INST.MENU**.
2. Press the rotary knob in the **DI SPLAY** menu.
 - ◁ **WATE R** = Domestic hot water temperature in the central section of the domestic hot water cylinder
 - ◁ **AIR INLET** = Air temperature at the air intake
 - ◁ **T_EV APOR** = Temperature of the evaporator
 - ◁ If **PV MODE** is deactivated:
 - **SHED DING** : Connection contact no. 1/low-tariff contact input (0: Contact opened; 1: Contact closed)
 - **FAN CONTR.** : Connection contact no. 2/hygrostat input (0: Contact opened; 1: Contact closed)
 - ◁ If **PV MODE** is activated:
 - **PV ECO** : Connection contact no. 1 input (0: Contact opened; 1: Contact closed)
 - **PV MAX** : Connection contact no. 2 input (0: Contact opened; 1: Contact closed)
3. Press the menu button to return to the original display.

8.4 Setting the anti-legionella function



Danger!

Risk of death from legionella.

Legionella multiply at temperatures below 60 °C.

- ▶ Ensure that the end user is familiar with all of the Anti-legionella measures in order to comply with the applicable regulations regarding legionella prevention.

The anti-legionella function heats the water in the product to a temperature between 60 °C and 70 °C. The default factory setting for the target temperature is 60 °C and the anti-legionella function is not carried out.

If the target temperature is below 60 °C, you can activate the anti-legionella function by setting the target temperature to a value between 60 °C and maximum 70 °C. The automatic cycle for heating the water is activated at 22:00.

If the target temperature for the cycle is not reached within 24 hours, the cycle stops and then starts again at the next interval deadline. If an anti-legionella cycle is interrupted by a time period in which the back-up heater is prevented from operating (high tariff or time programming), the anti-legionella function will be restarted in the next interval deadline.

- ▶ Observe the applicable regulations regarding legionella prevention.
- ▶ Turn the rotary knob to set the time interval (in days) for the anti-legionella function. **SET TINGS → ANTI -BACT. → INST.MENU**.
- ▶ Press the rotary knob.
- ▶ Select the time interval between two anti-legionella function charges.



Note

The time interval can be between 0 and 99 days.

- ▶ Press the rotary knob to confirm the selection.
- ▶ Press the menu button to return to the original display.

8.5 Selecting the load relief stage

Condition: Cable for low-tariff/high-tariff load relief connected

- ▶ Select the components that can be used during high-tariff periods.
 - Heat pump only
 - Heat pump and immersion heater
- ▶ Turn the rotary knob to set the mode. **INST.MENU → SET TINGS → SHED DING**.
 - ◁ 0 = No components may operate in the high-tariff periods
 - ◁ 1 = Only the heat pump may operate in the high-tariff periods
 - ◁ 2 = The heat pump and immersion heater may operate in the high-tariff periods



Note

When using a low-tariff connection, you should not set any additional time-programming.

- ▶ Press the menu button to return to the original display.
- ▶ If you are using a high-tariff connection, inform the end user of the optimal energy use.

8.6 Setting the minimum temperature

You can use the minimum temperature function to prevent the domestic hot water temperature falling below 38 °C. In doing so, the back-up heater (immersion heater) supports the heat pump until a domestic hot water temperature of 43 °C has been reached.

Depending on the parameter selection when setting the load relief stage, the minimum temperature function may not be available in high-tariff periods under certain circumstances.

INST.MENU → SET TINGS → T°C MINI

- ▶ Press the rotary knob.
- ▶ Turn the rotary knob and select a hot water temperature of 43 °C.
- ▶ Press the rotary knob to confirm the selection.
- ▶ Press the menu button to return to the original display.

8.7 Setting the fan mode

- ▶ Turn the rotary knob to set the mode **INST.MENU SET TINGS FAN MODE**.
 - ◁ 1 = Fan operates only when the heat pump is running. The fan speed automatically adjusts to the heat pump's requirements.
 - ◁ 2 = Fan operates only when the heat pump is running. The fan runs at maximum speed.
 - ◁ 3 = Fan operates only if the heat pump is running or if the external control system permits this (humidistat)

8.8 Setting the maximum heating time

1. If you switch off this function, the domestic hot water cylinder charging time is shortened. **INST.MENU → SET TINGS → MAX. TIME**.
2. Press the rotary knob.
3. Turn the rotary knob to set the maximum heating time via the heat pump (**Auto** /number of hours).
 - ◁ In **Auto** mode, the product optimises its use of energy sources (heat pump and back-up heater) in order to prevent the heating from starting less than five hours after a low-tariff period has begun.
 - When in the **Auto** setting, the product only uses the back-up heater during low-tariff periods and programmed time periods. The heat pump is used first. The back-up heater is switched on as late as possible.
 - If the unit is not connected to the energy supply company's high-/low-tariff contact, it may not recognise that the five-hour time period has started and consequently the **Auto** function may not work.
 - ◁ In "Number of hours" mode, the product optimises its use of energy sources (heat pump and back-up heater) in order to reach the set temperature within n hours of the heating starting.
 - The shorter the maximum heating time is set to, the more often the back-up heater is switched on and the higher the energy consumption and consequently the energy costs as a result.



Note

The amount of power available depends on the load relief level and the time period (Comfort, Eco, Frost protection, High/Low tariff) that have been programmed.

4. Press the rotary knob to confirm the selection.
5. Press the menu button to return to the original display.

8.9 Reading the meter status

1. If you want to read the product's counter statuses, select this menu **INST.MENU COUN TERS**.
2. Press the rotary knob in the **COUN TERS** menu.
 - ◁ No. 1 = Number of heat pump switching operations
 - ◁ No. 2 = Number of immersion heater switching operations
 - ◁ No. 3 = Function deactivated
 - ◁ No. 4 = Number of compressor operating hours
3. Press the menu button to return to the original display.

8.10 Locking the control elements

1. Turn the rotary knob until the **LOCK ING** menu is displayed.
 - If the control elements are blocked, you can only reset the fault codes or unblock the control elements **INST.MENU LOCK ING**.
2. Press the rotary knob to confirm.
3. Turn the rotary knob to set the automatic level of locking.
 - ◁ **no** = Automatic blocking is not active.
 - ◁ **Auto** = The control elements are blocked 60 seconds after the last entry. This is how you unblock the control elements (→ Page 20).
 - ◁ **Pro** = The control elements are blocked 300 seconds after the last entry. This is how you unblock the control elements (→ Page 20).
4. Press the rotary knob to confirm the selection.
5. Press the menu button to return to the original display.

8.10.1 Unblocking control elements in the Auto mode

1. Press and hold the menu button for three seconds.
2. Select the rotary knob **YES**.
3. Press the rotary knob to confirm the selection.
4. Press the menu button to return to the original display.

8.10.2 Unblocking control elements in the Pro mode

1. Press and hold the menu button for three seconds.
2. Press and hold the rotary knob and the clock button for three seconds.
3. Select the rotary knob **YES**.
4. Press the rotary knob to confirm the selection.
5. Press the menu button to return to the original display.

8.10.3 Manually locking the operator control elements

1. In the basic display, hold down the menu button and the clock button for three seconds.
2. Select the rotary knob **YES**.
3. Press the rotary knob to confirm the selection.
4. To lift manual locking, hold down the menu button for three seconds.

8.10.4 Preparing a blower door test

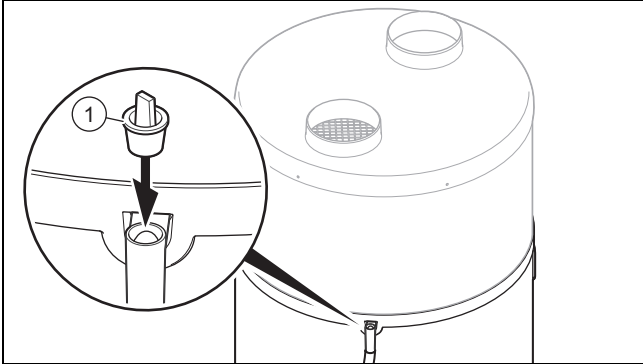

1. If you want to carry out a blower door test, you must seal the product's condensate overflow.
2. Use the supplied plug (1) to seal the condensate overflow.



Caution.

Risk of material damage when closing the condensate overflow

The condensate cannot flow out via the overflow if the waste-water pipework is blocked.

- ▶ After the blower-door test and before starting up the product, ensure that the plug for sealing the overflow has been removed.

3. You will need to remove the plug from the condensate overflow before starting up the product again.

8.11 Checking the immersion heater

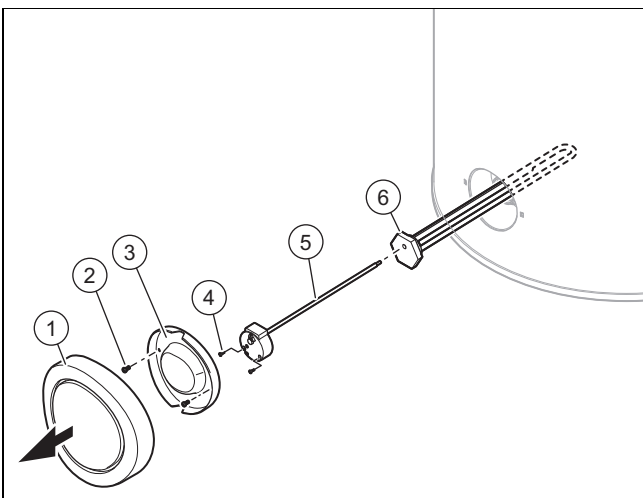

1. Press the on/off button.
2. Disconnect the product from the power grid.
3. Drain the product. (→ Page 22)

4. Remove the black decorative panel by pulling it forcefully to the side.
5. Undo the screws (2) on the lower covering hood (3).
6. Remove the lower covering hood (3).
7. Undo the screws (4) and pull the cables out of the immersion heater.
8. Remove the limit thermostat (5) from the immersion heater (6).
9. Unscrew the set-up unit along with the immersion heater (6) and its seal.
10. Check the scale deposition on the immersion heater.
11. Replace the seal.

9 Troubleshooting

9.1 Eliminating faults

- ▶ Before eliminating the fault, check that the product is supplied with power.
- ▶ Check whether the stopcocks are open.
- ▶ If fault messages appear, eliminate the fault after checking the table in the appendix.
Fault messages – Overview (→ Page 24)
- ▶ After eliminating the fault, start up the product once again.
- ▶ If you are unable to eliminate the fault, contact Customer Service.

9.2 Resetting parameters to factory settings

1. Turn the rotary knob until the **RESET PAR.** menu is displayed. – **INST.MENU RESET PAR..**
2. Press the rotary knob.
3. Turn the rotary knob to select **YES**.
4. Press the rotary knob to confirm the selection.
5. Press the menu button to return to the original display.

9.3 Resetting the safety cut-out

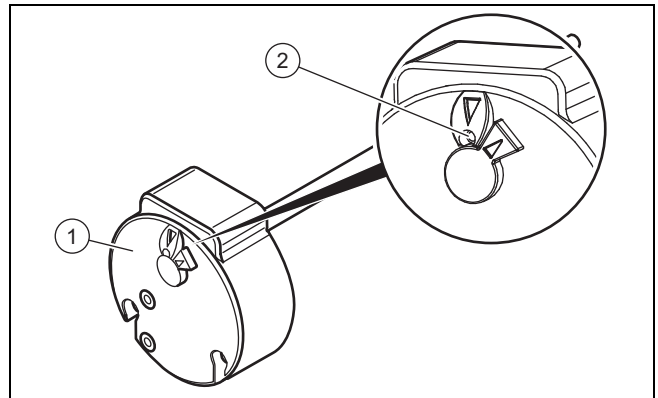

1. Before resetting the safety cut-out (1), check whether operation has been switched off by a low-tariff contact or time programming.
2. Check whether the safety cut-out for the auxiliary electric heating has been tripped as a result of overheating (> 87 °C), or as a result of a defect.
3. Remove the covering hood. (→ Page 10)
4. Ensure that the immersion heater is not calcified.
5. Press the button (2) to reset the safety cut-out.

**Note**

The safety cut-out settings must not be changed.

9.4 Replacing the power supply cable

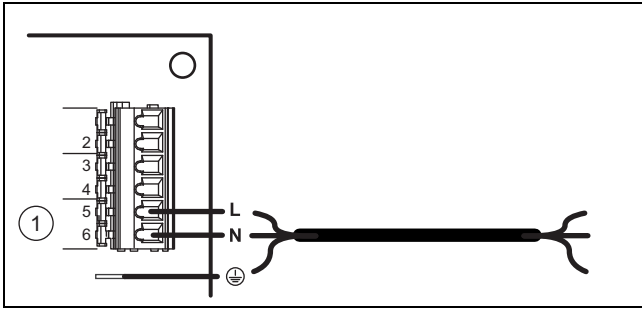

1. If the product's power supply cable is damaged, it must be replaced.

**Note**

The electrical installation must only be carried out by a competent person.

2. Remove the covering hood. (→ Page 10)
3. Remove the cover from the PCB.
4. Carry out the wiring. (→ Page 16)
5. Guide the power supply cable through the grommet on the rear of the electronics box.
6. Connect the power supply cable to the power supply connection for the product.

9.5 Completing repair work

1. Install the covering hood. (→ Page 10)
2. Establish the power supply.
3. Open all of the stopcocks.
4. Switch on the product. (→ Page 18)
5. Check that the product and the hydraulic connections work correctly and check for tightness.

10 Inspection and maintenance

10.1 Preparing the maintenance and repair work

1. Decommission the product.
2. Disconnect the product from the power grid.
3. Wait until the fan has come to a complete stop.
4. Close the stopcocks in the hydraulic circuit.
5. Close the stopcock upstream of the safety assembly on the cold water inlet.
6. Remove the covering hood. (→ Page 10)
7. Drain the product if you want to replace water-carrying components of the product.
8. Ensure that water does not drip on live components (e.g. the electronics box).
9. Use only new seals.

10.2 Observing inspection and maintenance intervals

- ▶ Adhere to the minimum inspection and maintenance intervals.

Annual inspection and maintenance work – Overview (→ Page 24)

10.3 Draining the product

1. Decommission the product.
2. Disconnect the product from the power grid.
3. Close the stopcock upstream of the safety assembly on the cold water inlet.
4. Ensure that the waste-water outlet is connected to the safety assembly.
5. Open the safety assembly valve and check that water is flowing into the drain.
6. Open the highest domestic hot water draw-off point in the house to drain the water pipes completely.
7. Once the water has completely drained out, close the safety assembly valve and the domestic hot water draw-off point again.

10.4 Procuring spare parts

The original components of the product were also certified by the manufacturer as part of the declaration of conformity. If you use other, non-certified or unauthorised parts during maintenance or repair work, this may result in the product no longer meeting the applicable standards, thereby voiding the conformity of the product.

We strongly recommend that you use original spare parts from the manufacturer as this guarantees fault-free and safe operation of the product. To receive information about the available original spare parts, contact the contact address provided on the back page of these instructions.

- ▶ If you require spare parts for maintenance or repair work, use only the spare parts that are permitted for the product.

10.5 Checking the safety group's expansion relief valve and the cylinder's expansion relief valve

1. Open all expansion relief valves by turning the plug.
2. Check whether the water is flowing into the tundish.
3. Check that the expansion relief valves are in the correct position and then check the pressure.
4. Check and, if required, clean the pressure reducer.

10.6 Checking the pre-charge pressure of the expansion vessel

1. Drain the product. (→ Page 22)
2. Measure the pre-charge pressure of the expansion vessel at the vessel valve.

Condition: Pressure <0.3 MPa (3 bar)

- ▶ Top up the expansion vessel in accordance with the static height of the heating installation, ideally with nitrogen, otherwise with air.
3. If water escapes from the valve of the expansion vessel, you must replace the expansion vessel.
 4. Fill the domestic hot water circuit. (→ Page 18)

10.7 Checking the inside of the cylinder

- ▶ Remove the immersion heater in order to check the inside of the cylinder. (→ Page 21)

11 Decommissioning

11.1 Decommissioning the product

- ▶ Press the on/off button.
- ▶ Disconnect the product from the power mains.
- ▶ Drain the product.

11.2 Arranging disposal of refrigerant



Warning.

Risk of damage to the environment

This heat pump contains the refrigerant R 290. The refrigerant must not be allowed to escape into the atmosphere.

- ▶ Refrigerant must only be disposed of by qualified competent persons.
-

The competent person who installed the heat pump must dispose of the refrigerant.

Personnel who are approved for energy recovery must have the relevant certification that corresponds to the valid regulations.

- ▶ In order to recycle the refrigerant, you must collect it in a suitable vessel prior to disposing of the product.

12 Customer service

For contact details for our customer service department, you can write to the address that is provided on the back page, or you can visit www.vaillant.co.uk.

13 Disposing of the packaging

- ▶ Dispose of the packaging correctly.
- ▶ Observe all relevant regulations.
- ▶ For detailed information refer to www.vaillant.co.uk.

Appendix

A Annual inspection and maintenance work – Overview

No.	Work
1	Check the connections for tightness.
2	Check the temperature and pressure expansion relief valve.
3	Check the expansion relief valve.
4	Check the pressure in the expansion vessel.
5	Check the domestic hot water output at the valve (if required, clean the filters).
6	Check that the safety devices are functioning properly.
7	Check the refrigerant circuit for leak-tightness.
8	Check the hydraulic circuit for leak-tightness.
9	Check that the safety assembly is working properly.
10	Check whether the components of the refrigerant circuit show any signs of rust or traces of oil.
11	Check the unit's components for wear.
12	Check whether the unit's components are defective.
13	Check that the cables are securely seated on the connection terminals.
14	Check the electrical installation in accordance with the applicable standards and regulations.
15	Check the product's earthing.
16	Check the evaporator for ice formation.
17	Remove the dust from power supply connections.
18	Clean the evaporator carefully to avoid damaging the fins. Ensure that air circulation through the entire circuit, including the air intake, is not impeded.
19	Check that the fan runs freely and is clean.
20	Check whether the condensate drains off without any problems.
21	Check the scale deposition on the immersion heater. If the layer of limescale is thicker than 5 mm, you must replace the immersion heater.
22	Record the inspection/maintenance work carried out.

B Fault messages – Overview

Fault code	Description	Possible cause	Solution	Temporary operation
buS	<ul style="list-style-type: none"> – PCB defective – Bus connection to the display is faulty – Display defective 	<ul style="list-style-type: none"> – Overvoltage in the power grid – Cabling fault in the power supply connection (low-tariff contact or external fan control system) – Damage during transport 	<ul style="list-style-type: none"> – Replacing the PCB – Replacing the display PCB – Replacing the display connection cable 	Product decommissioned.
T_AI R	Air temperature sensor defective (extracted air)	<ul style="list-style-type: none"> – Sensor defective – Sensor not connected to the PCB – Sensor cable damaged 	Replace the sensor	Heat pump decommissioned. The selected back-up heater keeps the water temperature at 38 °C.
T_DE FROST	Evaporator temperature sensor defective (Defrosting temperature)	<ul style="list-style-type: none"> – Sensor defective – Sensor not connected to the PCB – Sensor cable damaged 	Replace the sensor	Heat pump decommissioned. The selected back-up heater keeps the water temperature at 38 °C.
T_WA TER	Water temperature sensor defective	<ul style="list-style-type: none"> – Sensor defective – Sensor not connected to the PCB – Sensor cable damaged 	Replace the sensor	Heat pump decommissioned.

Fault code	Description	Possible cause	Solution	Temporary operation
CLOC K	Time	<ul style="list-style-type: none"> - Overvoltage in the power grid - Damage during transport 	<ul style="list-style-type: none"> - Replacing the display PCB - Replacing the display connection cable 	Operating times are no longer considered: Target temperature for domestic hot water is permanently maintained (no signal on connection plug numbers 1 and 2).
OVER PRESS.	Overpressure inside the heat pump	<ul style="list-style-type: none"> - No water in the domestic hot water cylinder - Water temperature too high (> 75 °C) - Water temperature sensor removed from the domestic hot water cylinder - Water temperature sensor defective 	<ul style="list-style-type: none"> - Checking that the product is correctly filled with water and purged - Replacing the water temperature sensor - Checking that the water temperature sensor is sitting correctly in the cylinder dry pocket 	Heat pump decommissioned. The reset must be implemented manually. Possible operation of the back-up heater.
FREQ.DEFRO.	Excessive de-icing	<ul style="list-style-type: none"> - Air flow too low - Air inlet/outlet opening blocked - Air pipe blocked - Pipeline too long or too many elbows - Evaporator contaminated - Air temperature sensor missing from the air flow 	<ul style="list-style-type: none"> - Checking that the air flows through the entire pipework system without any problems - Check the pipe length - Checking the status of any filters present in the air pipes - Checking that the evaporator is free of dust - Positioning the air temperature sensor correctly 	Heat pump decommissioned. The selected back-up heater keeps the water temperature at 38 °C.
LOW PRES.	Low pressure inside the heat pump	<ul style="list-style-type: none"> - Air flow too low - Air inlet/outlet opening blocked - Air pipe blocked - Fan blocked or defective - Evaporator contaminated and blocked - Evaporator frozen - Air temperature sensor missing from the air flow 	<ul style="list-style-type: none"> - Checking that the fan is running - Checking that the air flows through the entire pipework system without any problems - Check the pipe length - Checking the status of any filters present in the air pipes - Checking that the evaporator is free of dust - Positioning the air temperature sensor correctly 	Heat pump decommissioned. The selected back-up heater keeps the water temperature at 38 °C.
OVER HEAT	Domestic hot water overheating (Water temperature > 87 °C)	<ul style="list-style-type: none"> - Water temperature sensor defective - Water temperature sensor removed from the domestic hot water cylinder 	Checking that the sensor is correctly positioned in the pocket	Heat pump decommissioned. Resetting is effected automatically.
ANTI -BACT.	Anti-legionella function incomplete. Water-heating could not be finished.	<ul style="list-style-type: none"> - Water flow too high - Set target cylinder temperature too high - Malfunction of the electric back-up heater - Use of the electric back-up heater not authorised 	<ul style="list-style-type: none"> - Manually start the new cycle for heating the water - Reducing the target cylinder temperature - Checking, cleaning or replacing the electric back-up heater - In the settings, authorise the use of the electric back-up heater (e.g. for high-tariff periods) 	The product remains in operation.

Fault code	Description	Possible cause	Solution	Temporary operation
PV MODE	Incorrect temperature sensor readings	<ul style="list-style-type: none"> – The air temperature sensor and the defrosting sensor have been inverted on the PCB – The defrosting sensor and the water temperature sensor have been inverted on the PCB – The defrosting sensor is connected to the air connection plug. The air temperature sensor is connected to the water connection plug and the water temperature sensor is connected to the defrosting connection plug 	Connecting the temperature sensors to the PCB correctly	Heat pump decommissioned.
	Incorrect defrosting sensor readings	Defrosting sensor incorrectly installed on the pipe. Air temperature is measured	Re-establishing contact between the defrosting sensor and the pipe	
	Heat pump out of gas	Leak in the cooling circuit	Finding and repairing the leak before filling the cooling circuit	
	Expansion valve decommissioned	Break in the copper pipe for the expansion valve following interference or due to contact with a vibrating component.	Replacing the expansion valve	
	Compressor decommissioned and safety cut-out activated	Compressor defective	Replacing the compressor	
PV ECO	Incorrect temperature sensor readings	<ul style="list-style-type: none"> – The air temperature and the water temperature sensors have been inverted on the PCB. – The defrosting sensor is connected on the water connection plug. The water temperature sensor is connected to the air connection plug, and the air temperature sensor is connected to the defrosting connection plug. 	Connecting sensors to the PCB correctly	Product decommissioned.
PV MAX	Incorrect temperature sensor readings	The defrosting sensor is connected on the water connection plug. The water temperature sensor is connected to the air connection plug, and the air temperature sensor is connected to the defrosting connection plug.	Connecting sensors to the PCB correctly	Product decommissioned.
T°PV ECO	Incorrect defrosting and hot water temperature sensor readings	The defrosting sensor and the water temperature sensor have been inverted on the PCB.	Connecting sensors to the PCB correctly	Heat pump decommissioned.
ERR. 08	Incorrect measurements by the defrosting sensor	The defrosting sensor is defective.	Replace the sensor	The product works in alternating operation with the heat pump.
EPrO	Display card has a storage problem	<ul style="list-style-type: none"> – Display card is damaged – Display connection cable is damaged 	<ul style="list-style-type: none"> – Replacing the display card – Replacing the display connection cable 	Product decommissioned.

C Installer level – Overview

Setting level	Values		Unit	Increment, select, explanation	Factory setting
	Min.	Max.			
INST.MENU → PV MODE →					
PV MODE	Current value			YES, no	no
INST.MENU → PV MODE → PRIORITY					
PRIORITY	Current value			YES: PV MODE has higher priority than frost protection and eco mode; no: PV MODE has lower priority than frost protection and eco mode	YES
INST.MENU → DI SPLAY →					
WATE R	Current value		°C		
AIR INLET	Current value		°C		
T_EV APOR	Current value		°C		
PV ECO	Current value			Only visible if PV MODE = YES 0: Contact opened; 1: Contact closed	
PV MAX	Current value			Only visible if PV MODE = YES 0: Contact opened; 1: Contact closed	
SHED DING	Current value			Only visible if PV MODE = no 0: Contact opened; 1: Contact closed	
FAN CONTR.	Current value			Only visible if PV MODE = no 0: Contact opened; 1: Contact closed	
INST.MENU → SET TINGS →					
ANTI -BACT.	60	70	°C	1 °C; YES, no; number of days	no
SHED DING	Current value			Only visible if PV MODE = no 0: Product out of operation during high tariff 1: Only heat pump in operation during high tariff 2: Heat pump and immersion heater in operation during high tariff	1
T°C MINI	43	43	°C	43 °C; no	no
FAN MODE	Current value			1 = Fan operates only when the heat pump is running. The fan speed automatically adjusts to the heat pump's requirements. 2 = Fan operates only when the heat pump is running. The fan runs at maximum speed. 3: Fan is controlled by an external humidistat If PV MODE = YES: Only 1 and 2 can be selected	1
MAX. TIME	2	24	h	no, Auto, number of hours	no
INST.MENU → RESE T PAR. →					
RESE T PAR.	Current value			YES, no	no
INST.MENU → COUN TERS →					
COUN TERS	Current value			No. 1: Heat pump start cycles No. 2: Immersion heater start cycles No. 3: Not used No. 4: Compressor operating hours	
INST.MENU → LOCK ING →					
LOCK ING	Current value			no; Auto; Pro	no

D Electronics box wiring diagram

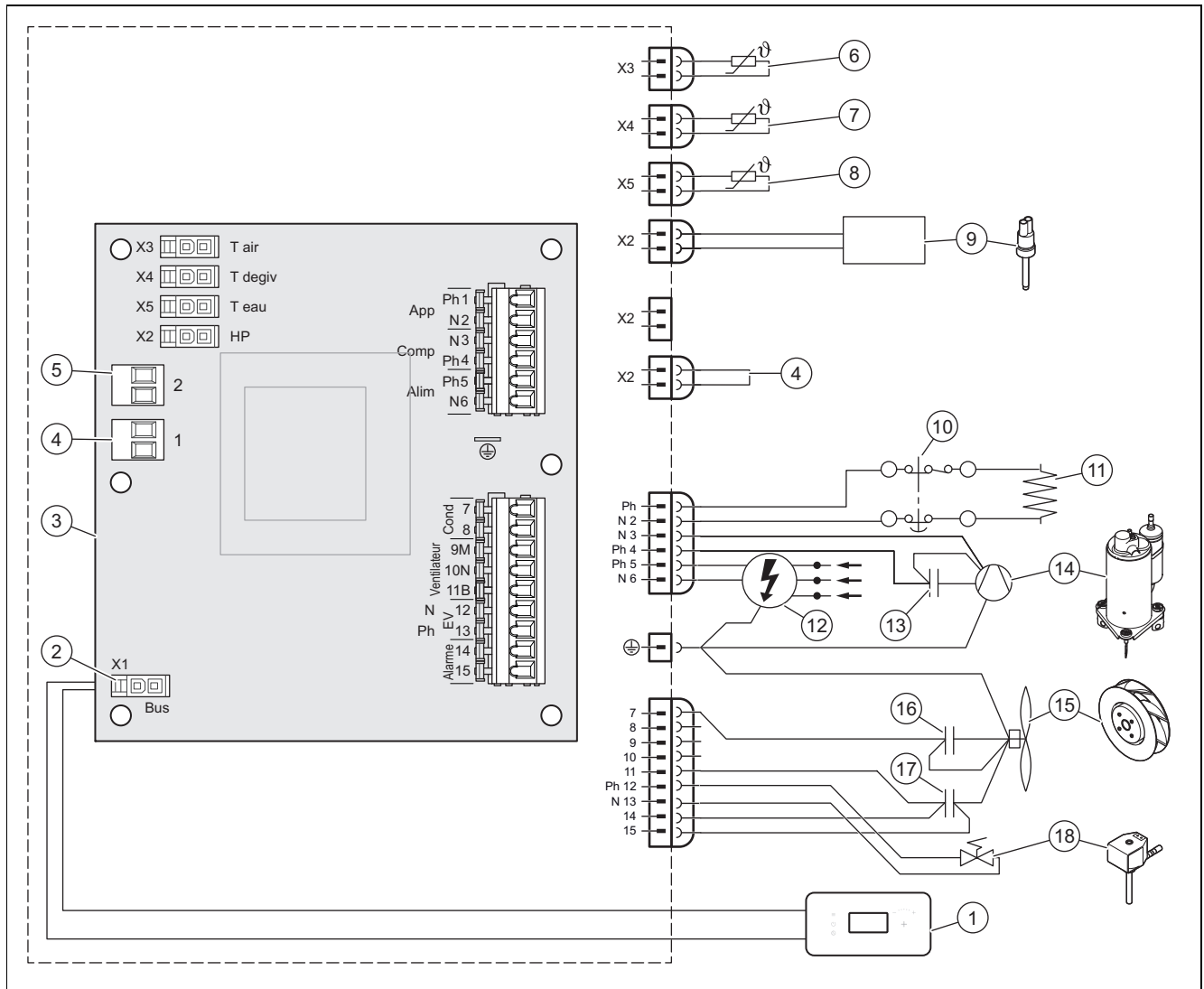

- | | |
|---|--|
| 1 | Control panel |
| 2 | Control panel connection plug |
| 3 | Main PCB |
| 4 | Connection plug no. 1: Low tariff or lower level of electrical energy generated by the photovoltaic installation |
| 5 | Connection plug no. 2: Fan control system or upper level of electrical energy generated by the photovoltaic installation |
| 6 | Air temperature sensor |
| 7 | Defrosting temperature sensor |
| 8 | Water temperature sensor |

- | | |
|----|-----------------------|
| 9 | Pressure switch |
| 10 | Safety cut-out, 87 °C |
| 11 | Immersion heater |
| 12 | 230 V power supply |
| 13 | 20 μF condenser |
| 14 | Compressor |
| 15 | Fan |
| 16 | 2 μF condenser |
| 17 | 5.5 μF condenser |
| 18 | Defrosting valve |

E Heat pump output curves

Validity: aroSTOR VWL B 200/5

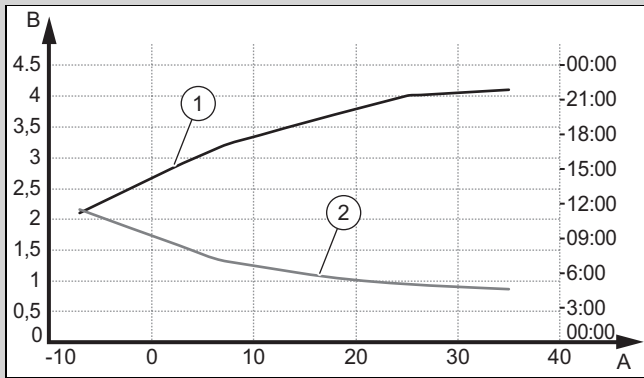

A Air temperature in °C

B Working figure (COP)

1 COP at a cold water temperature of 10 °C for a target temperature of 55 °C (EN 16147:2017/extraction cycle L)

2 Heating time at a water temperature of 10 °C for a target temperature of 55 °C (EN 16147:2017/extraction cycle L)

Validity: aroSTOR VWL B 270/5

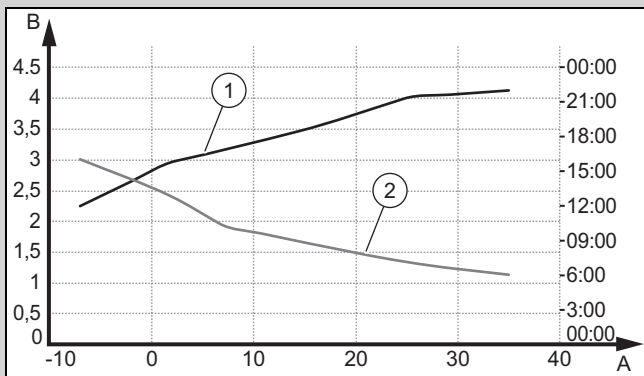

A Air temperature in °C

B Working figure (COP)

1 COP at a cold water temperature of 10 °C for a target temperature of 55 °C (EN 16147:2017/extraction cycle L)

2 Heating time at a water temperature of 10 °C for a target temperature of 55 °C (EN 16147:2017/extraction cycle L)

F Maximum water temperature

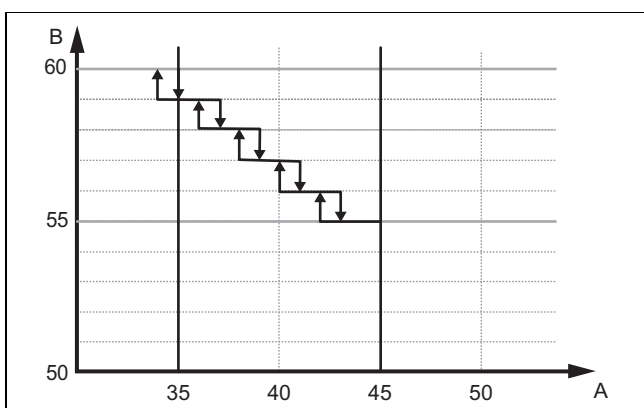

A Air temperature (°C)

B Water temperature that can be reached in heat pump mode P106 (°C)

The maximum temperature of the domestic hot water using only the heat pump depends on the air temperature.

At an air temperature of 35 °C, the maximum water temperature that can be reached is 60 °C. At 45 °C, the maximum temperature is reduced to 55 °C. The water temperature is reduced by 1 °C for every 2 °C air temperature.

The temperature difference between the set value and the maximum value that can be reached in the heat pump mode is regulated by the immersion heater.

G Commissioning Checklist

Benchmark Commissioning and Servicing Section

It is a requirement that the cylinder is installed and commissioned to the manufacturers instructions and the data fields on the commissioning checklist completed in full.

To instigate the cylinder guarantee the cylinder needs to be registered with the manufacturer within one month of the installation.

To maintain the cylinder guarantee it is essential that the cylinder is serviced annually by a competent person who has been trained on the cylinder installed. The service details should be recorded within Benchmark.



www.benchmark.org.uk

MAINS PRESSURE HOT WATER STORAGE SYSTEM COMMISSIONING CHECKLIST

This Commissioning Checklist is to be completed in full by the competent person who commissioned the storage system as a means of demonstrating compliance with the appropriate Building Regulations and then handed to the customer to keep for future reference.

Failure to install and commission this equipment to the manufacturer's instructions may invalidate the warranty but does not affect statutory rights.

Customer Name _____ Telephone Number _____
Address _____
Cylinder Make and Model _____
Cylinder Serial Number _____
Commissioned by (print name) _____ Registered Operative ID Number _____
Company Name _____ Telephone Number _____
Company Address _____ Commissioning Date _____

To be completed by the customer on receipt of a Building Regulations Compliance Certificate*:

Building Regulations Notification Number (if applicable) _____

ALL SYSTEMS PRIMARY SETTINGS (indirect heating only)

Is the primary circuit a sealed or open vented system? Sealed Open
What is the maximum primary flow temperature? _____ °C

ALL SYSTEMS

What is the incoming static cold water pressure at the inlet to the system? _____ bar
Has a strainer been cleaned of installation debris (if fitted)? Yes No
Is the installation in a hard water area (above 200ppm)? Yes No
If yes, has a water scale reducer been fitted? Yes No
What type of scale reducer has been fitted? _____
What is the hot water thermostat set temperature? _____ °C
What is the maximum hot water flow rate at set thermostat temperature (measured at high flow outlet)? _____ l/min
Time and temperature controls have been fitted in compliance with Part L of the Building Regulations? Yes
Type of control system (if applicable) Y Plan S Plan Other
Is the cylinder solar (or other renewable) compatible? Yes No
What is the hot water temperature at the nearest outlet? _____ °C
All appropriate pipes have been insulated up to 1 metre or the point where they become concealed Yes

UNVENTED SYSTEMS ONLY

Where is the pressure reducing valve situated (if fitted)? _____
What is the pressure reducing valve setting? _____ bar
Has a combined temperature and pressure relief valve and expansion valve been fitted and discharge tested? Yes No
The tundish and discharge pipework have been connected and terminated to Part G of the Building Regulations Yes
Are all energy sources fitted with a cut out device? Yes No
Has the expansion vessel or internal air space been checked? Yes No

THERMAL STORES ONLY

What store temperature is achievable? _____ °C
What is the maximum hot water temperature? _____ °C

ALL INSTALLATIONS

The hot water system complies with the appropriate Building Regulations Yes
The system has been installed and commissioned in accordance with the manufacturer's instructions Yes
The system controls have been demonstrated to and understood by the customer Yes
The manufacturer's literature, including Benchmark Checklist and Service Record, has been explained and left with the customer Yes

Commissioning Engineer's Signature _____

Customer's Signature _____
(To confirm satisfactory demonstration and receipt of manufacturer's literature)

*All installations in England and Wales must be notified to Local Authority Building Control (LABC) either directly or through a Competent Persons Scheme. A Building Regulations Compliance Certificate will then be issued to the customer.

SERVICE RECORD

It is recommended that your hot water system is serviced regularly and that the appropriate Service Record is completed.

Service Provider

Before completing the appropriate Service Record below, please ensure you have carried out the service as described in the manufacturer's instructions.

SERVICE 1 Date

Engineer Name

Company Name

Telephone Number

Comments

Signature

SERVICE 2 Date

Engineer Name

Company Name

Telephone Number

Comments

Signature

SERVICE 3 Date

Engineer Name

Company Name

Telephone Number

Comments

Signature

SERVICE 4 Date

Engineer Name

Company Name

Telephone Number

Comments

Signature

SERVICE 5 Date

Engineer Name

Company Name

Telephone Number

Comments

Signature

SERVICE 6 Date

Engineer Name

Company Name

Telephone Number

Comments

Signature

SERVICE 7 Date

Engineer Name

Company Name

Telephone Number

Comments

Signature

SERVICE 8 Date

Engineer Name

Company Name

Telephone Number

Comments

Signature

SERVICE 9 Date

Engineer Name

Company Name

Telephone Number

Comments

Signature

SERVICE 10 Date

Engineer Name

Company Name

Telephone Number

Comments

Signature

H Technical data

Technical data – General

	aroSTOR VWL B 200/5 UK	aroSTOR VWL B 270/5 UK
Nominal capacity	197.5 l	269 l
Outer diameter	634 mm	634 mm
Height	1,458 mm	1,783 mm
Weight (when empty)	55 kg	68 kg
Weight (full)	255 kg	338 kg
Material of the product container	Stainless steel	Stainless steel
Heat insulation	Polyurethane foam 50 mm	Polyurethane foam 50 mm
Maximum pressure in the drinking water circuit	0.6 MPa (6.0 bar)	0.6 MPa (6.0 bar)
Maximum inlet pressure	0.6 MPa (6.0 bar)	0.6 MPa (6.0 bar)
Pressure reducer pressure setting	0.3 MPa (3.0 bar)	0.3 MPa (3.0 bar)
Expansion valve pressure setting	0.6 MPa (6.0 bar)	0.6 MPa (6.0 bar)
Maximum pressure of the temperature and pressure relief valve	0.7 MPa (7.0 bar)	0.7 MPa (7.0 bar)
Maximum temperature of the temperature and pressure relief valve	90 °C	90 °C
Length of the temperature and pressure relief valve	900 mm	1,245 mm
Post-heating time in accordance with EN 12897	06:20	09:28
Permanent heat losses	1.61 kWh/24 hrs	1.77 kWh/24 hrs
Kiwa certification number	1906704/AMD1	1906704/AMD1

Technical data – Electrical specifications

	aroSTOR VWL B 200/5 UK	aroSTOR VWL B 270/5 UK
Voltage and frequency of the product's power supply	230 V – 50 Hz	230 V – 50 Hz
Max amperage of the power supply circuit	8 A	8 A
Length of the electrical cable supplied	1.5 m	1.5 m
IP rating	IPX4	IPX4
Nominal heat output of the electric back-up heater	1,200 W	1,200 W
Heat input of the electric back-up heater	7 W/cm ²	7 W/cm ²
Fuse	8 A	8 A

Technical data – Connections

	aroSTOR VWL B 200/5 UK	aroSTOR VWL B 270/5 UK
Connections for the domestic hot water circuit	3/4" outside thread, cylindrical	3/4" outside thread, cylindrical
Connecting the temperature and pressure relief valve	F 1/2"	F 1/2"
Air connections (inlet and outlet)	160 mm	160 mm

Technical data – Specifications for the heat pump

* In accordance with EN 16147:2017

	aroSTOR VWL B 200/5 UK	aroSTOR VWL B 270/5 UK
Refrigerant type	R 290	R 290
Refrigerant volume for complete filling	0.15 kg	0.15 kg
Max. overpressure in the heat pump	2.5 MPa (25.0 bar)	2.5 MPa (25.0 bar)
Max. low pressure in the heat pump	1.5 MPa (15.0 bar)	1.5 MPa (15.0 bar)
Permitted air temperature	-7 to 45 °C	-7 to 45 °C
Sound power level LpA (V1/V2)	40/43 dB	40/43 dB

	aroSTOR VWL B 200/5 UK	aroSTOR VWL B 270/5 UK
Sound power level LWA (V1)	50/52 dB	50/52 dB
Nominal heat output of the heat pump (water temperature: 55 °C)	700 W	700 W
Nominal heat output of the heat pump (water temperature: 45 °C)	1,420 W	1,420 W
Coefficient of performance (COP _{DHW} (outdoor air temperature: 7 °C, extraction cycle: L)*	2.99	3.00
Maximum usable domestic hot water volume v_{max} (outdoor air temperature: 7 °C, extraction cycle: L)*	250.8 l	334.5 l
Reference domestic hot water temperature Θ'_{WH} (outdoor air temperature: 7 °C, extraction cycle: L)*	54.6 °C	53.7 °C
Heat-up time (environmental air temperature: 7 °C, extraction cycle: L)*	6.57 h	9.26 h
Power consumption during standby periods P_{es} (outdoor air temperature: 7 °C, extraction cycle: L)*	25 W	27 W

Index

B	
Basic diagram.....	3
C	
Calling up the installer level.....	18
CE marking.....	8
Checking the pre-charge pressure of the expansion vessel	22
Combustion air	5
Competent person.....	3
Completing repair work	22
Completing, repair work	22
Corrosion.....	5
D	
Decommissioning	23
Disposal, packaging	23
Disposing of the packaging	23
Documents	6
Drain pipe	15
Drain valve	14
Draining the product.....	22
E	
Electrical installation.....	16
Electricity.....	3
F	
Fault codes.....	21
Fault messages	21
Frost	4
H	
Handing over to the operator.....	18
Heating installation, leaking.....	5
I	
Immersion heater	21
Inspection work	22, 24
Installation	10
Installation site.....	3, 5
Installing the protective cover.....	10
Intended use.....	3
Isolator devices	23
M	
Maintenance work	22, 24
P	
Power supply cable	22
Preparing the maintenance and repair work	22
Protective cover.....	10
Q	
Qualification.....	3
R	
Regulations	5
S	
Safety assembly	14
Safety cut-out	21
Safety device.....	3
Spare parts.....	22
Switching off	23
Switching off the product.....	23
Switching on the product.....	18
System, leaking	5
T	
Tool	4
Transport.....	4
U	
Unpacking	9
V	
Voltage	3
W	
Water hardness	4
Wiring	16

Supplier

Vaillant Group UK Ltd.

Nottingham Road ■ Belper ■ Derbyshire ■ DE56 1JT ■ Great Britain

Telephone 0330 100 3143

info@vaillant.co.uk ■ www.vaillant.co.uk



0020285063_07

Publisher/manufacture

Vaillant GmbH

Berghauser Str. 40 ■ 42859 Remscheid ■ Deutschland, Germany

Tel. +49 (0)2191 18 0 ■ Fax +49 (0)2191 18 2810

info@vaillant.de ■ www.vaillant.de

© These instructions, or parts thereof, are protected by copyright and may be reproduced or distributed only with the manufacturer's written consent.

Subject to technical modifications.